



Missouri Department of Transportation

Bridge Division

Bridge Design Manual

Section 3.20

Revised 10/01/2004

[Click Here for Index](#)

3.20.1 General

- 1.1 General, Effective Span Length, and Design Fill
- 1.2 Standard Box Culverts (2 sheets)

3.20.2 Design

- 2.1 Dead Loads
- 2.2 Live Loads and Horizontal Pressures (4 sheets)
- 2.3 Structural Model (4 sheets)
- 2.4 Design Procedure (8 sheets)
- 2.5 Criteria for Steel Reinforcement (3 sheets)
- 2.6 Design Example 1: Live Load Analysis Using Influence Line Method (12 sheets)
- 2.7 Design Example 2: Steel Reinforcement Design for J4 bar (8 sheets)
- 2.8 Design Example 3: Steel Reinforcement Design for J5 bar (3 sheets)
- 2.9 Design Example 4: Edge Beam Design (5 sheets)

3.20.3 Dimensions

- 3.1 Barrel Section (3 sheets)
- 3.2 Wings and Curtain Walls (3 sheets)
- 3.3 Headwalls, Edge Beams, and Collar Beams

3.20.4 Details

- 4.1 Joints (2 sheets)
- 4.2 Reinforcement (6 sheets)
- 4.3 Survey Data for Plans (4 sheets)
- 4.4 Miscellaneous

1.1 General, Effective Span Length, and Design Fill

General

Concrete box culverts are classified as “Bridges” if the distance along the centerline of roadway from stream face to stream face of exterior walls is more than 20'-0”.

Box culverts should be analyzed and designed as rigid frames. All standard box culverts have bottom slabs. For box culverts built on solid rock, a non-standard box culvert without a bottom slab may be considered.

In a situation where a box culvert is likely subjected to foundation settlement, collar beams should be provided at transverse joints to prevent large differential settlement between adjoined sections. See Figure 3.20.4.2-4 for details.

For culvert extensions, use the current design method as described herein regardless of what design method was used for the existing culvert. Match opening dimensions of new extension with those of the existing culvert when possible. Otherwise use larger opening dimensions. See Section 3.20.4.4 for the cutting details of the existing culvert.

Effective Span Length

AASHTO 3.24.1.2

For a single span box, the effective span can be the distance between center to center of supports but need not exceed clear span plus thickness of slab. For multiple spans, the effective span length except for structural model (Section 3.20.2.3) is the distance between stream faces (i.e., clear span length).

Design Fill

Design fill is defined as the earth fill depth used in culvert analysis and design resulting in the greatest structural capacity. Earth fill is a backfill or fill that is placed on the top slab. Earth fill depth is defined as the distance between the top of top slab to the top of earth fill or roadway surface as shown in Figure 3.20.1.2-1.

For culverts having an earth fill that varies in depth due to roadway gradient, sloping barrel, or superelevation, the earth fill depth shall be determined as follows:

If the culvert or any part of the section to be designed is under a roadway, the design of the box or full cut section between transverse joints is based on an earth fill depth at a high or low quarter point, whichever produces maximum effects, between roadway shoulders.

If a section is under the fill slope outside of roadway shoulders, use an earth fill depth at a high quarter point between fill depths of that section.

Earth fill depth other than stated above should not be used without the permission of the Structural Project Manager.

1.2 Standard Box Culverts

Details of standard box culverts are available in Missouri Standard Plans for Highway Construction. A typical box culvert is shown in Figure 3.20.1.2-1. In this figure, a cut section is defined as the section between two transverse joints.

There are four types of standard box culverts shown in Figure 3.20.1.2-2. Type 1 is a squared box with straight wings; Type 2 is a squared box with flared wings (upstream end only); Type 3 is a skewed box with straight wings; and Type 4 is a skewed box with flared wings (upstream end only).

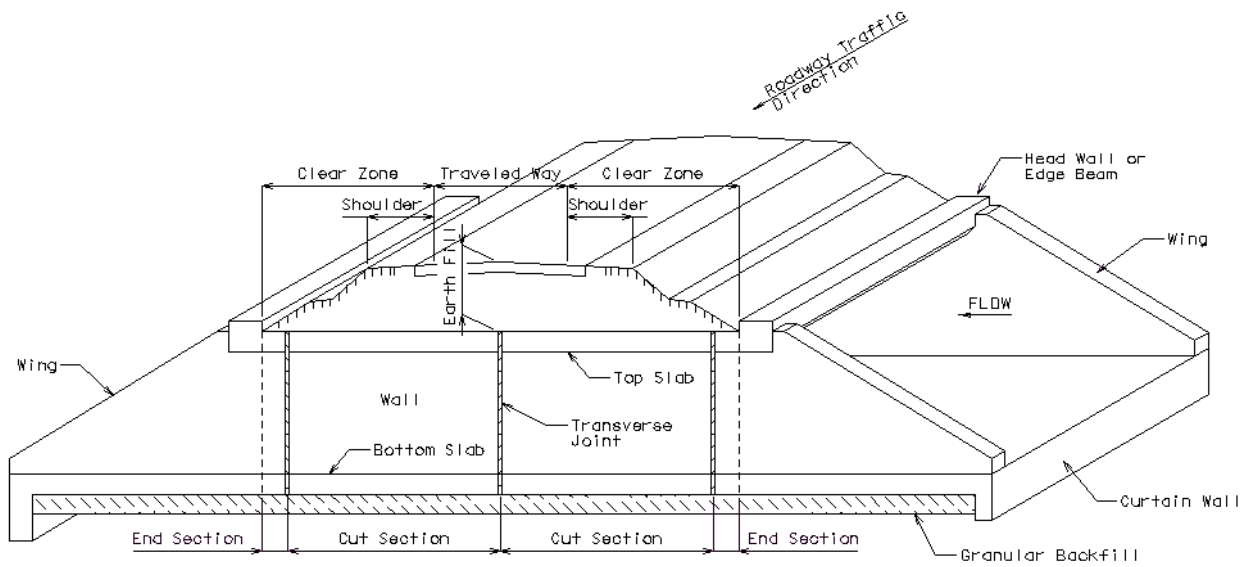

Figure 3.20.1.2-1 Three dimensional view of typical box culvert

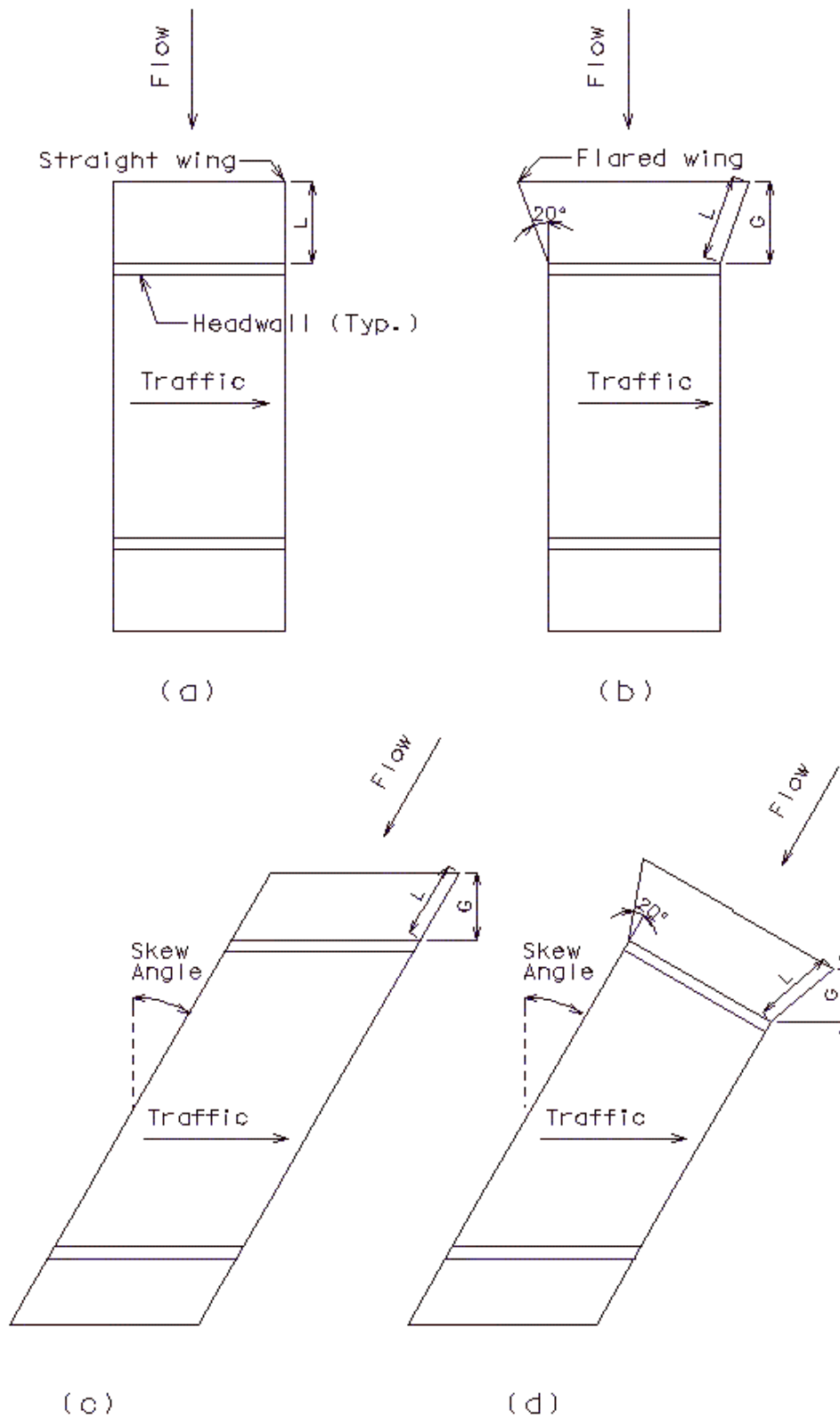

Figure 3.20.1.2-2 Four types of standard box culverts (a) Type 1: square with straight wings, (b) Type 2: square with flared wings, (c) Type 3: skewed with straight wings, and (d) Type 4: skewed with flared wings.

2.1 Dead Loads

Dead loads are weight of earth fill and self-weight of concrete members as shown in Figure 3.20.2.3-1.

(1) Top slab (DL1)

Earth fill weight and self-weight of slab shall be applied uniformly on the top slab. As shown in Figure 3.20.2.3-1, DL1 represents earth fill weight and self-weight of top slab.

(2) Bottom slab (DL2)

Total dead load (DL2) from self-weight of walls and DL1 shall be applied uniformly on the bottom slab. See Figure 3.20.2.3-1 for load directions.

(3) Walls

Neglect self-weight for wall design only.

(4) Wing walls

Neglect self-weight.

(5) Headwalls and edge beams

Earth fill and slab weights are assumed to apply as a triangular load on the beam when the beam is skewed. Self-weight of beam shall be applied uniformly along the beam length. See Section 3.20.2.3 for details of load application.

Material Properties

The following properties shall be used in the design of box culverts.

Density of concrete, $\gamma_c = 150 \text{ lbs/ft.}^3$

Density of earth fill, $\gamma_e = 120 \text{ lbs/ft.}^3$

Compressive strength of concrete, $f'c = 4000 \text{ psi}$

Minimum yield strength of reinforcement steel, $f_y = 60000 \text{ psi}$

2.2 Live Loads and Horizontal Pressures

AASHTO 3.7

All box culverts shall be designed for either HS20 or HS20 Modified truck. Use HS20 Mod. truck for box culverts located in the Commercial Load Zone or on the National Highway System. Otherwise, HS20 truck should be used. Additionally, all box culverts should also be analyzed and designed for the Military Tandem Axle Loading.

Live loads shall be considered under clear zones in the same manner as under roadways (or traveled way) as depicted in Figure 3.20.3.1-1.

(1) Top slab

The effect of live load distribution varies with different earth fill depths as follows:

For earth fill depth < 2'-0", Figure 3.20.2.2-1(a) shows that a concentrated wheel load is uniformly distributed over a distributed width, E, where this width is perpendicular to a one-foot strip of the top slab. Then, the equivalent concentrated live load (LL1) as shown in Figure 3.20.2.2-1(b) is equal to the wheel load (P) divided by E. The distributed width, E, is determined as:

AASHTO 3.24.3.2

$$E = 4 + 0.06S \leq 7.0' \quad \text{Equation (2.2-1)}$$

Where

E = distributed width in feet

S = effective span length in feet

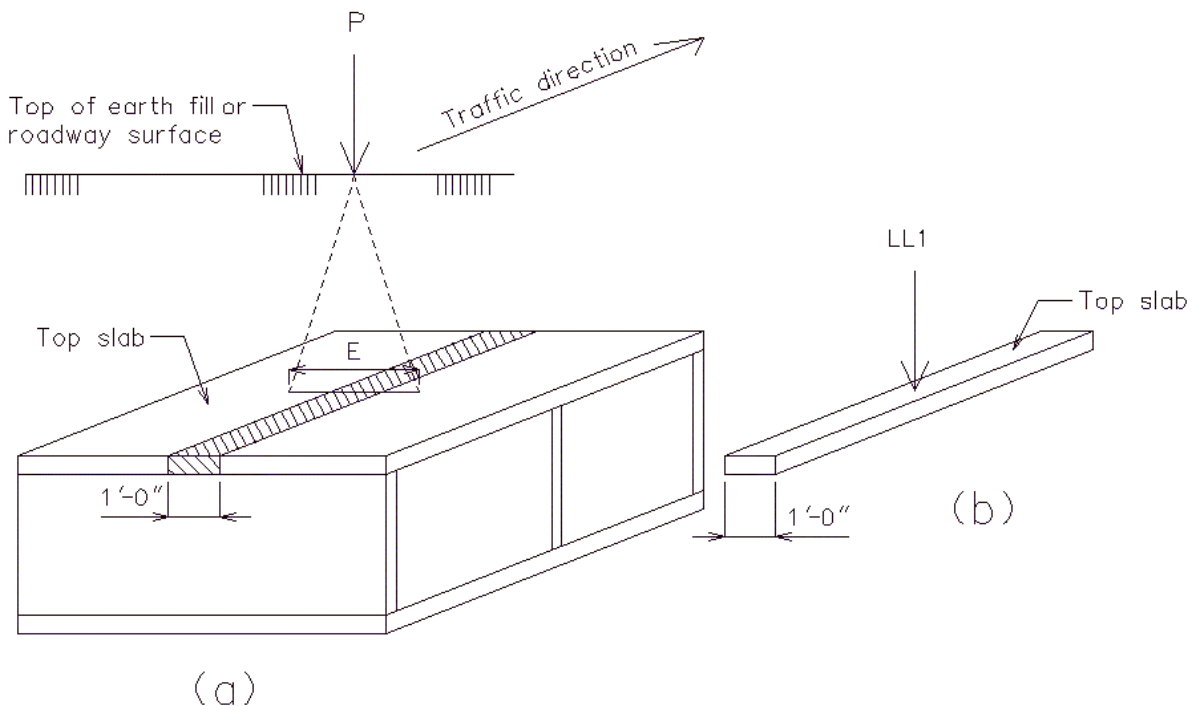

Figure 3.20.2.2-1 Distribution of live load for earth fill < 2'-0" (a) A wheel load is uniformly distributed over width, E (b) equivalent concentrated live load (LL1) on a one-foot strip width

For earth fill depth $\geq 2'-0"$, Figure 3.20.2.2-2(a) shows that a concentrated wheel load is uniformly distributed over a squared area with equal sides, E , where these sides are perpendicular and parallel to a one-foot strip of the top slab. Then, the equivalent uniform live load (LL1 per unit length) as shown in Figure 3.20.2.2-2(b) is equal to the wheel load (P) divided by the square of E . The distributed width, E , is determined as:

AASHTO 6.4.1

$$E = 1.75H \quad \text{Equation (2.2-2)}$$

Where

E = distributed width in feet

H = earth fill depth in feet

AASHTO 6.4.2

When such distributed widths in Figure 3.20.2.2-2(b) from several concentrated wheel loads overlap, the total width of distributions should not exceed the total width of the supporting slab. See Section 3.20.2.3 for applications of distributed live load.

For single span boxes, the effect of live load may be neglected when the earth fill depth is more than $8'-0"$ and exceeds the effective span length; for multiple spans, it may be neglected when the earth fill depth exceeds the distance between fill faces of end supports.

When the calculated live load and impact moment in concrete slabs, based on the distribution of the wheel load(s) in Equation (2.2-2) through earth fill, exceeds the live load and impact moment calculated according to Equation (2.2-1), the least moment shall be used.

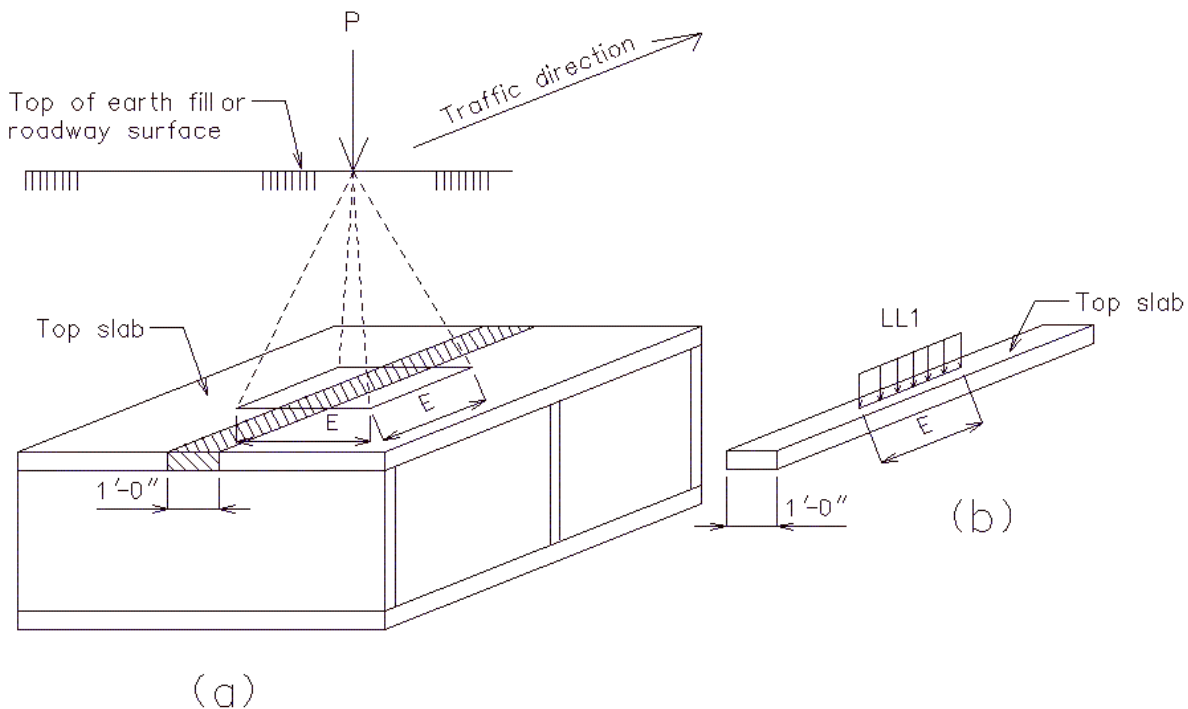

Figure 3.20.2.2-2 Distribution of live load for earth fill $\geq 2'-0"$ (a) A wheel load is uniformly distributed over a squared area (b) equivalent uniform live load (LL1) on a one-foot strip width

(2) Bottom slab

The distribution of live load to the bottom slab (LL2) as shown in Figure 3.20.2.3-1 may be based on AASHTO 17.6.4.3. Alternatively, the uniform distributed live load, defined as total live load with impact divided by total length of spans, can be used for analysis.

$$LL2 = \frac{\sum LL1}{(\text{total span length})} \quad \text{Equation (2.2-3)}$$

Where

LL2 = equivalent uniform live load per linear foot

LL1 = live load from the top slab

(3) Walls

AASHTO 3.20.3 and 6.4.2

Live load surcharge, SUR, is equal to 2'-0" of soil height times the density of earth fill. SUR shall be applied uniformly at fill faces of exterior walls (Figure 3.20.2.3-1). Live load surcharge and live load should be neglected if the earth fill depth is more than 8'-0" and exceeds the effective span length for single span box. For multiple spans, it should be neglected when the earth fill depth exceeds the distance between fill faces of end supports.

(4) Headwalls and edge beams

AASHTO 3.24.8.2

For single span, the moment calculated from Equation (2.2-4) due to live load can be used for headwall or edge beam design. For multiple spans, the moment due to live load can be reduced by 20 percent of the moment calculated from Equation (2.2-4). The appropriate impact factor should be used.

$$M = 0.1PL \quad \text{Equation (2.2-4)}$$

Where

P = a concentrated wheel load of 16 or 20 kips due to HS20 or HS20 Mod. truck in kips, respectively

L = effective span length of beam in feet

Horizontal Pressures

AASHTO 6.2.1

(1) Barrel section

The following properties shall be used on all box culvert designs.

Minimum equivalent fluid pressure, $P_{e1} = 30 \text{ lbs/ft.}^3$

Maximum equivalent fluid pressure, $P_{e2} = 60 \text{ lbs/ft.}^3$

Minimum water pressure, $P_{w1} = 0.0 \text{ lbs/ft.}^3$

Maximum water pressure, $P_{w2} = 62.4 \text{ lbs/ft.}^3$

Maximum or minimum equivalent fluid pressure (EP) due to soil shall be applied at fill faces of exterior walls. Water pressure (WP) shall also be applied at these walls to simulate a case when a culvert is full of water. Only exterior walls are subjected to these loads as shown in Figure 3.20.2.3-1.

(2) Wing section

Coulomb active soil pressure or Rankine active formula may be used for horizontal pressures at exterior wing walls only. Neglect passive pressure due to water. See Section 3.20.2.3 for structural model. For vertical reinforcement design, Coulomb active force can be calculated as:

$$P_a = \frac{1}{2} \gamma_s K_a H^2 \quad \text{Equation (2.2-5)}$$

$$K_a = \frac{\sin^2(\theta + \phi)}{\sin^2(\theta) \sin(\theta - \delta) \left[1 + \sqrt{\frac{\sin(\phi + \delta) \sin(\phi - \beta)}{\sin(\theta - \delta) \sin(\theta + \beta)}} \right]^2} \quad \text{Equation (2.2-6)}$$

Where

P_a = resultant force of active earth pressure

K_a = Coulomb active earth coefficient

H = design height of wing wall (Figure 3.20.2.3-2)

γ_s = effective unit weight of backfill

θ = slope of wall face at fill face in degree

β = backfill slope in degree

ϕ = internal friction angle of backfill in degree (conservatively, use 27° if backfill property is not available)

$\delta \approx (2/3)\phi$ (angle of wall friction)

Horizontal reinforcement shall be designed only when the wing is non-standard or built on a rock foundation. Then, Coulomb active force should be determined as:

$$P_h = A \gamma_s K_a H_i \quad \text{Equation (2.2-7)}$$

Where

P_h = resultant force of active earth pressure

H_i = height from the top of wing to the centroid of a one-foot width section (Figure 3.20.2.3-3)

A = rectangular area of a one-foot width section (Figure 3.20.2.3-3)

Impact Factor

AASHTO 3.8.1.2

AASHTO 3.8.2.3

Impact factor shall be considered for all members. The following impact factors shall be used for a given earth fill:

Earth Fill Depth	Impact Factor
0'-0" to 1'-0"	30%
1'-1" to 2'-0"	20%
2'-1" to 2'-11"	10%
3'-0" and over	0%

2.3 Structural Model

AASHTO 8.8.2

In the analysis of continuous and rigid frame members, the span length or height should be the distance from center to center (the geometric centers) of members. For box culverts on rock, the effective height is defined as the height from rock elevation (Figure 3.20.3.1-2) to the geometric center of the top slab.

Structural Model for Cut Sections

A structural model is analyzed as a rigid frame structure with a one-foot strip width perpendicular to the centerline of culvert (Figures 3.20.2.2-1 and 3.20.2.2-2). As shown in Figure 3.20.2.3-1, the boundary conditions are 1) no lateral and vertical displacements at right end of the bottom slab and 2) no vertical displacement at left end of the bottom slab. For non-standard box culverts on a rock foundation, a pinned support at each wall is assumed at the rock elevation.

See Figure 3.20.2.3-1 for details of loads and load directions. DL1 is dead loads of earth fill and top slab; DL2 is dead loads from DL1 and walls; SUR is a live load surcharge; EP is equivalent fluid pressures; WP is water pressure; and LL1 and LL2 are live loads specified in Section 3.20.2.2.

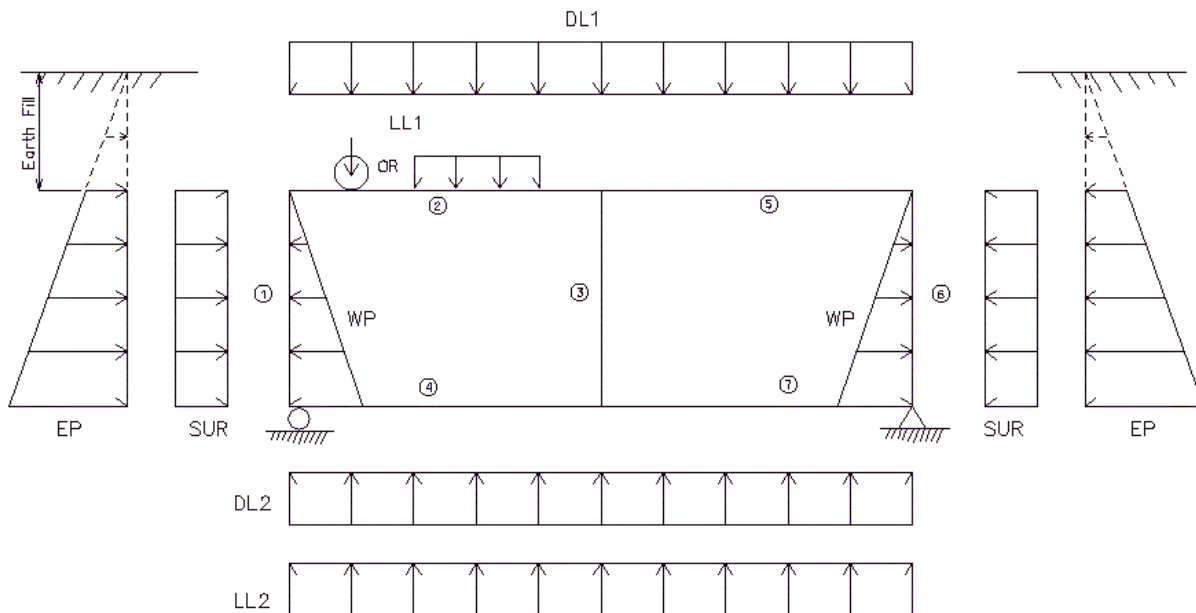

Figure 3.20.2.3-1 Typical structural model with loads

Structural Model for Wing Walls

Figure 3.20.2.3-2 shows a typical cross section of a wing wall. Self-weight, water pressure, and live load surcharge are neglected. Only active earth pressure is applied at exterior wing wall as described in Section 3.20.2.2. The resultant force P_a of active pressure is applied at $(1/3)H$ from the bottom of wing wall where H is a design wing height. Since the wing wall height varies along its length due to wing slope, the design wing height can be determined at a high quarter point of wing length. The wing wall should be analyzed and designed as a vertical cantilever beam with a one-foot width perpendicular to the bottom slab. See Example 3 for wing wall design.

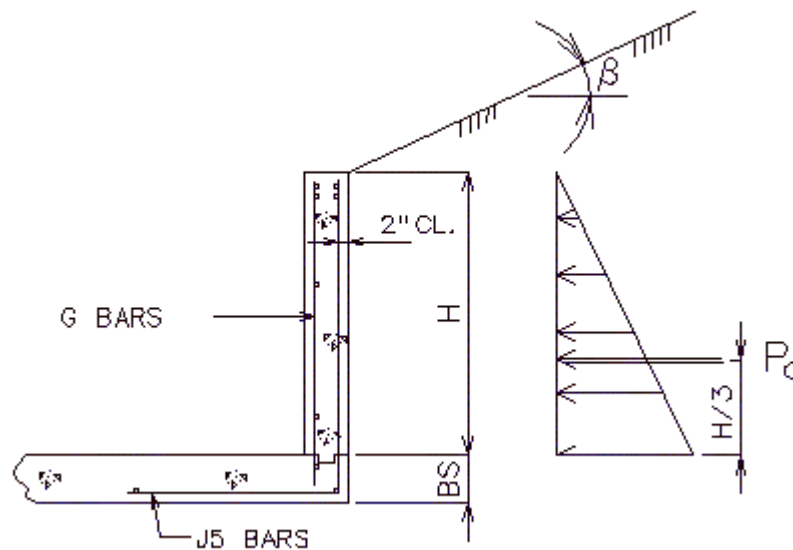

Figure 3.20.2.3-2 Typical cross section of wing wall

For wing walls on rock, vertical reinforcement should be analyzed and designed the same procedure as wing wall with the bottom slab as mentioned above. Horizontal reinforcement should be analyzed and designed as a horizontal cantilever beam with a one-foot width in vertical direction. The procedure is similar to wing design of integral end bent (Bridge Manual Section 3.77). Figure 3.20.2.3-3 shows elevation view of exterior wing wall and structural model. Force P_h from Equation (2.2-7) shall be applied at a centroid of a one-foot width section where the centroid is located at height H_i and half of length L_i . Moment and shear should be determined for each one-foot width section and checked at the critical section as shown in the figure.

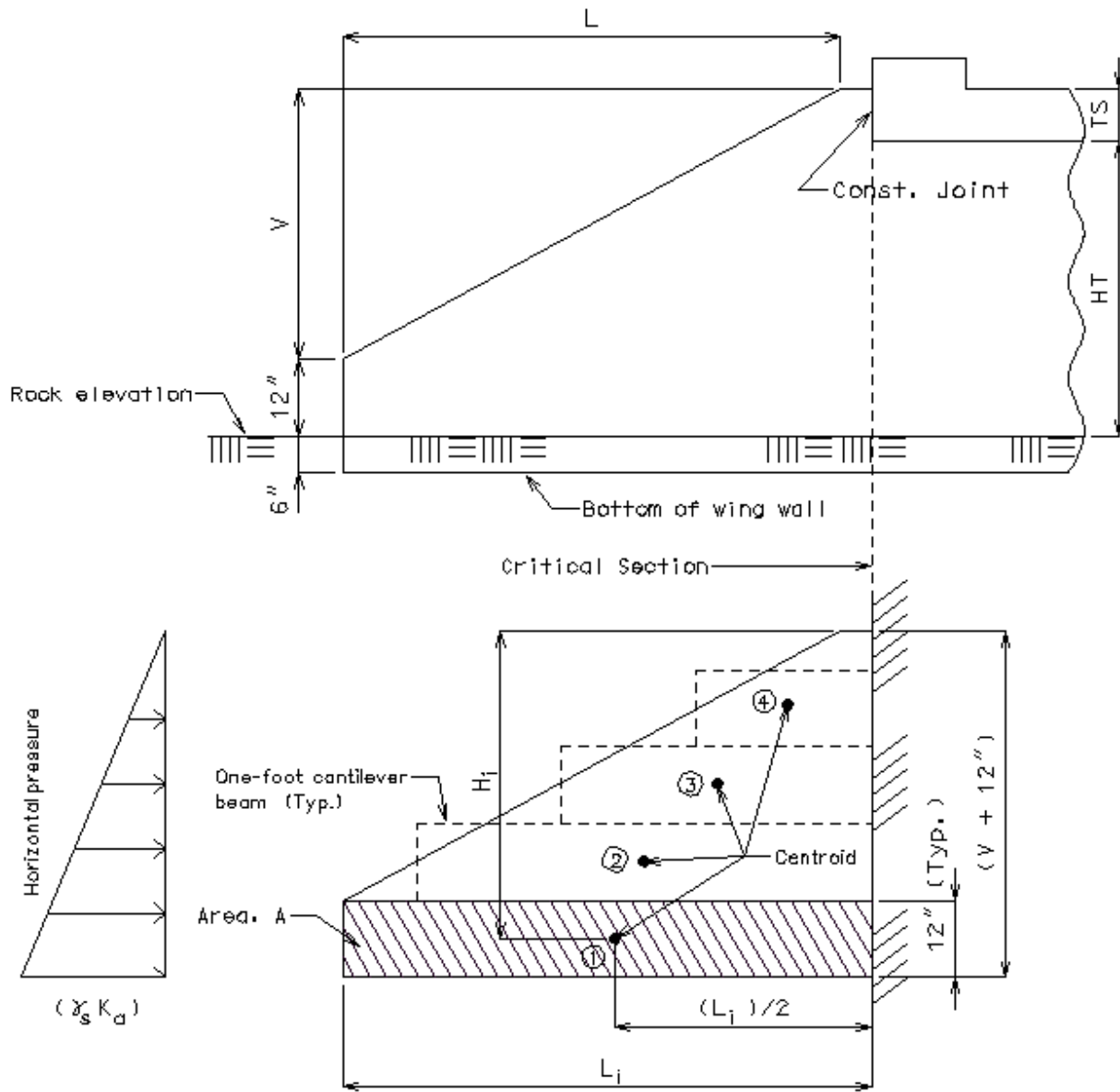

Figure 3.20.2.3-3 Structural model for designing horizontal reinforcement of wing wall on rock

Structural Model for Headwalls and Edge beams

A simple model of headwall or edge beam is shown in Figure 3.20.2.3-4. Dead load due to weights of slab and earth fill is computed based on a triangular hatched area (Figure 3.20.2.3-4(a)). Then, assume a half of this dead load to be supported by the wall and the other half supported by the beam as shown in Figure 3.20.2.3-4(b). In addition, self-weight of beam and earth fill weight above the beam shall be applied as uniform load along the beam. The beam is treated as a continuous beam with simple supports. See Example 4 for edge beam design.

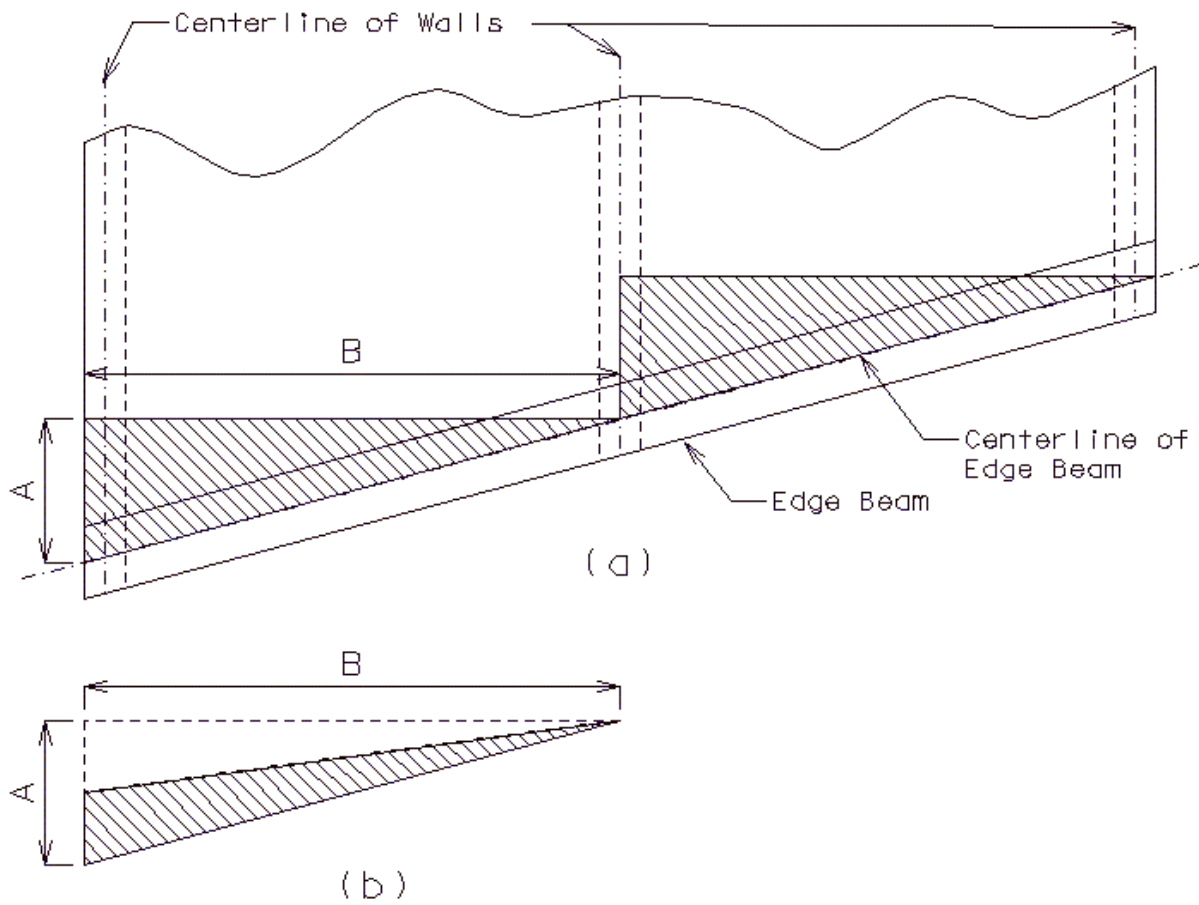

Figure 3.20.2.3-4 Partial plan view of double box culvert showing edge beam and dead loads (a) triangular hatched areas represent dead loads (b) half of dead loads to be carried by edge beam

2.4 Design Procedure

Design Methods

Load Factor Design should be used.

Service Load should be used for crack control and fatigue checks.

Load Combination

AASHTO 3.22

Load combination for Group I should be used for design of all box culverts.

$$\text{Group I} = \gamma[\beta_d D + \beta_l(L + I) + \beta_e E + WP] \quad \text{Equation (2.4-1)}$$

Where

$\gamma = 1.3$ and 1.0 for Load Factor and Service Load Designs, respectively

$\beta_l = 1.67$ and 1.0 for Load Factor and Service Load Designs, respectively

$\beta_d = 1.0$

$\beta_e = 1.0$ for rigid culverts (use for both Load Factor and Service Load Designs)

D = dead loads

L = live loads

I = impact factor

E = equivalent fluid pressure

WP = water pressure

Strength Reduction Factors

AASHTO 17.6.4.6

The following reduction factors, ϕ , shall be used.

$\phi = 0.90$ for moment

$\phi = 0.85$ for shear

$\phi = 0.70$ for axial compression member with tied stirrups (AASHTO 8.16.1.2.2)

Flexure Strength

AASHTO 8.8.2 and 8.16.3

If the analysis shows that a maximum moment occurs at the end of a member, then the maximum design moment should be determined at stream faces of support. Moment capacity (i.e., ϕM_n) of a member at a cross section should not be less than the factored moment, M_u , at that cross section. When moment capacity in Equation (2.4-2) is less than factored moment, increase steel area or thickness of the member.

$$\phi M_n \geq M_u \quad \text{Equation (2.4-2)}$$

$$M_n = \left[A_s f_y \left(d - \frac{a}{2} \right) \right] \quad \text{Equation (2.4-3)}$$

$$a = \frac{A_s f_y}{0.85(f_c')b} \quad \text{Equation (2.4-4)}$$

A required steel area can be determined by Equation (2.4-5).

$$A_s = \rho b d \quad \text{Equation (2.4-5)}$$

$$\rho = \frac{0.85 f_c'}{f_y} \left[1 - \sqrt{1 - \frac{2R_u}{0.85 f_c'}} \right] \quad \text{Equation (2.4-6)}$$

$$R_u = \frac{M_u}{\phi b d^2} \quad \text{Equation (2.4-7)}$$

Where

A_s = required steel area in in.²

b = section width

d = effective depth of a section (Note: thickness of monolithic wearing or protective surface shall be excluded at the compressive face of the section where applicable. See Section 3.20.2.5)

ρ = required steel ratio (a ratio of steel to concrete areas of a section)

M_u = factored moment

ϕ = strength reduction factor for moment

AASHTO 8.16.3.1

Maximum steel ratio, ρ_{\max} , shall not exceed 75% of the balanced steel ratio, ρ_b .

$$\rho_{\max} = 0.75 \rho_b \quad \text{Equation (2.4-8)}$$

$$\rho_b = \frac{0.85 \beta_1 f_c'}{f_y} \left(\frac{87000}{87000 + f_y} \right) \quad \text{Equation (2.4-9)}$$

Where

ρ_{\max} = maximum steel ratio

ρ_b = balanced steel ratio

$\beta_1 = 0.85$ for $f_c \leq 4000$ psi

Minimum flexural reinforcement, ρ_{\min} , can be calculated as:

$$\rho_{\min} = 1.7 \left(\frac{h}{d} \right)^2 \frac{\sqrt{f_c'}}{f_y} \quad \text{Equation (2.4-10)}$$

Where

ρ_{\min} = minimum steel ratio

h = section thickness

The following criteria should be checked to ensure that adequate steel area is provided for the section:

- 1) If $\rho_{\min} \leq \rho \leq \rho_{\max}$, then use ρ for computing steel area.
- 2) If $\rho_{\min} > \rho \geq \rho_{\max}$, then use smaller steel ratio of (4/3 of ρ) or (ρ_{\min}).

Shear Strength

AASHTO 8.16.6.1.2

Maximum design shear should be checked at a distance “d” from the stream face of support where “d” is the effective depth of a section. Shear capacity (i.e., ϕV_n) should be provided only by shear strength of concrete and it should not be taken less than factored shear, V_u .

$$\phi V_n \geq V_u \quad \text{Equation (2.4-11)}$$

AASHTO 8.16.6.3.2

When the shear capacity of slabs and walls specified in Equation (2.4-11) is less than factored shear, increase thickness of the section. For headwalls and edge beams, strength of shear reinforcement, in addition to concrete shear strength, can be considered. Therefore, steel area of shear reinforcement may be computed as follow:

$$A_v = \frac{V_s(s)}{f_y d} \quad \text{Equation (2.4-12)}$$

$$V_s = \frac{V_u}{\phi} - V_c \quad \text{Equation (2.4-13)}$$

Where

A_v = required steel area of shear reinforcement in in.²

V_s = shear force to be resisted by shear reinforcement

V_c = nominal shear strength provided by concrete and given in Equation (2.4-14) or (2.4-15)

s = spacing of shear reinforcement steel

AASHTO 8.16.6.2 and 8.16.6.7

Nominal shear strength should be determined as followings:

$$V_c = 2\sqrt{f'_c}(bd) \quad \text{for earth fill} < 2' \quad \text{Equation (2.4-14)}$$

$$V_c = \left(2.14\sqrt{f'_c} + 4600\rho \frac{V_u d}{M_u} \right) bd \quad \text{for earth fill} \geq 2' \quad \text{Equation (2.4-15)}$$

but $V_c \geq 3\sqrt{f'_c}(bd)$ for single span boxes

$V_c \leq 4\sqrt{f'_c}(bd)$ for all others

Where

V_u = factored shear

M_u = factored moment occurring simultaneously with V_u at a section considered

$$\frac{V_u d}{M_u} \leq 1.0$$

For headwalls, edge beams, and wing walls, use Equation (2.4-14) to determine a nominal shear strength.

Slenderness Effect in Wall Members

AASHTO 8.16.5

When a wall member is subjected to axial load or combined flexure and axial loads, the design calculations should check for slenderness effects. A magnified moment shall be used in the design if the slenderness effect is considered.

The slenderness effect may be neglected if Equation (2.4-16) is satisfied.

$$\frac{KL_u}{r} < 34 - \left(12 \frac{M_{1b}}{M_{2b}} \right) \quad \text{Equation (2.4-16)}$$

Where

K = 0.65 for fixed-fixed end conditions (AASHTO Appendix C)

= 0.80 for fixed-pinned end conditions (AASHTO Appendix C)

L_u = unsupported length (clear wall height)

r = radius of gyration and may be assumed as 0.3 times member thickness

M_{1b} = smaller end moment of a wall member

M_{2b} = larger end moment of a wall member

$\frac{M_{1b}}{M_{2b}}$ = positive or negative value if the member is bent in single or double curvature, respectively.

(1) Magnified moment

A magnified factored moment, M_m, shall be computed as follows:

$$M_m = \delta_b M_b \quad \text{Equation (2.4-17)}$$

$$\delta_b = \frac{C_m}{1 - \frac{P_u}{\phi P_c}} \geq 1.0 \quad \text{Equation (2.4-18)}$$

$$C_m = 0.6 + 0.4 \left(\frac{M_{1b}}{M_{2b}} \right) \geq 0.4 \quad \text{Equation (2.4-19)}$$

$$P_c = \frac{\pi^2 EI}{(KL_u)^2} \quad \text{Equation (2.4-20)}$$

$$EI = \frac{E_c I_g}{(1 + \beta_d)} \quad \text{Equation (2.4-21)}$$

Where

M_m = magnified moment

δ_b = magnified factor for a member braced against sideways

M_b = larger end moment of a wall member due to factored loads braced against sideways

β_d = ratio of maximum dead load moment to maximum total load moment and it is always positive

- E_c = modulus of elasticity of concrete
- I_g = moment of inertia of a gross concrete section
- P_c = critical buckling load
- P_u = factored axial load
- $\phi = 0.7$ for axial compression with tied stirrups (strength reduction factor)

When there is no moment at either end of the wall member or the computed end eccentricities (i.e., $e = \frac{M_u}{P_u}$) are less than the minimum eccentricity in Equation (2.4-22), moment M_b in Equation (2.4-17) shall be replaced with the minimum moment in Equation (2.4-23).

AASHTO 8.16.5.2.8

$$e_{\min} = (0.6 + 0.03h) \quad \text{Equation (2.4-22)}$$

$$M_{\min} = e_{\min} P_u \quad \text{Equation (2.4-23)}$$

Where

M_{\min} = minimum moment due to minimum eccentricity

e_{\min} = minimum eccentricity in inches

h = section thickness in inches

(2) Wall Capacity due to combined axial and flexural loads

AASHTO 8.16.4.2.4

When a wall member is subjected to both axial and flexural loads, the design of such member should consider axial load – flexural moment interaction effect (i.e., “interaction diagram”). Figure 3.20.2.4-1(a) shows a typical interaction diagram. A simplified interaction diagram can approximately be generated using straight-line curve as shown in Figure 3.20.2.4-1(b).

The following procedure is a guideline for generating the simplified interaction diagram.

- 1) Determine the maximum design axial capacity (ϕP_o):

$$\phi P_o = (\alpha)(\phi) \left\{ 0.85 f_c' (A_g - A_{st}) + A_{st} f_y \right\} \quad \text{Equation (2.4-24)}$$

Where

A_g = gross area of a cross section in in.²

A_{st} = total area of steel reinforcement in in.²

$\phi = 0.7$ for axial compression with tied stirrup (strength reduction factor)

$\alpha = 0.8$ for axial compression with tied stirrup (AASHTO 8.16.4.2.1)

- 2) Determine the balanced point ($\phi P_b, \phi M_b$): Axial load (ϕP_b) and moment (ϕM_b) are determined by Equations (2.4-25) and (2.4-26), respectively.

$$\phi P_b = \phi \left[0.85 f_c' (b)(a_b) + A'_s f'_s - A_s f_y \right] \quad \text{Equation (2.4-25)}$$

$$\phi M_b = \phi \left[0.85 f_c' (b)(a_b) \left(d - d'' - \frac{a_b}{2} \right) + A'_s f'_s (d - d' - d'') + A_s f_y d'' \right]$$

Equation (2.4-26)

$$f'_s = 87000 \left[1 - \left(\frac{d'}{d} \right) \left(\frac{87000 + f_y}{87000} \right) \right] \leq f_y \quad \text{Equation (2.4-27)}$$

Where

$$a_b = \frac{87000}{(87000 + f_y)} \beta_1 d$$

A_s = total area of tensile reinforcement in in.²

A'_s = total area of compressive reinforcement in in.²

d = effective depth in inches (Note: thickness of monolithic wearing surface shall be excluded at the compressive face of the member where applicable. See Section 3.20.2.5)

d' = a distance from concrete compressive surface to the centerline of compressive reinforcement in inches

d'' = a distance from centerline of tensile reinforcement to the centroid of member's gross section in inches

$$\phi = 0.7$$

- 3) Determine the pure bending design moment (ϕM_o): If Equation (2.4-28) is satisfied. Then, the bending moment is determined by Equation (2.4-29). Otherwise, use Equation (2.4-3) with the consideration of flexural strength reduction factor.

$$\frac{A_s - A'_s}{bd} \geq 0.85 \beta_1 \left(\frac{f'_c d'}{f_y d} \right) \left(\frac{87000}{87000 - f_y} \right) \quad \text{Equation (2.4-28)}$$

$$\phi M_o = \phi \left[(A_s - A'_s) f_y \left(d - \frac{a}{2} \right) + A'_s f_y (d - d') \right] \quad \text{Equation (2.4-29)}$$

Where

$$a = \frac{(A_s - A'_s) f_y}{0.85 (f'_c) b}$$

$$\phi = 0.7$$

AASHTO 8.16.1.2.2

- 4) Strength reduction factor, ϕ , may be increased linearly from a value of compressive member to a value of flexural member as the design axial load, ϕP_n , decreases from smaller value of ϕP_b or Equation (2.4-30) to zero. See Figure 3.20.2.4-1(b) for details.

$$P = 0.1 f'_c A_g \quad \text{Equation (2.4-30)}$$

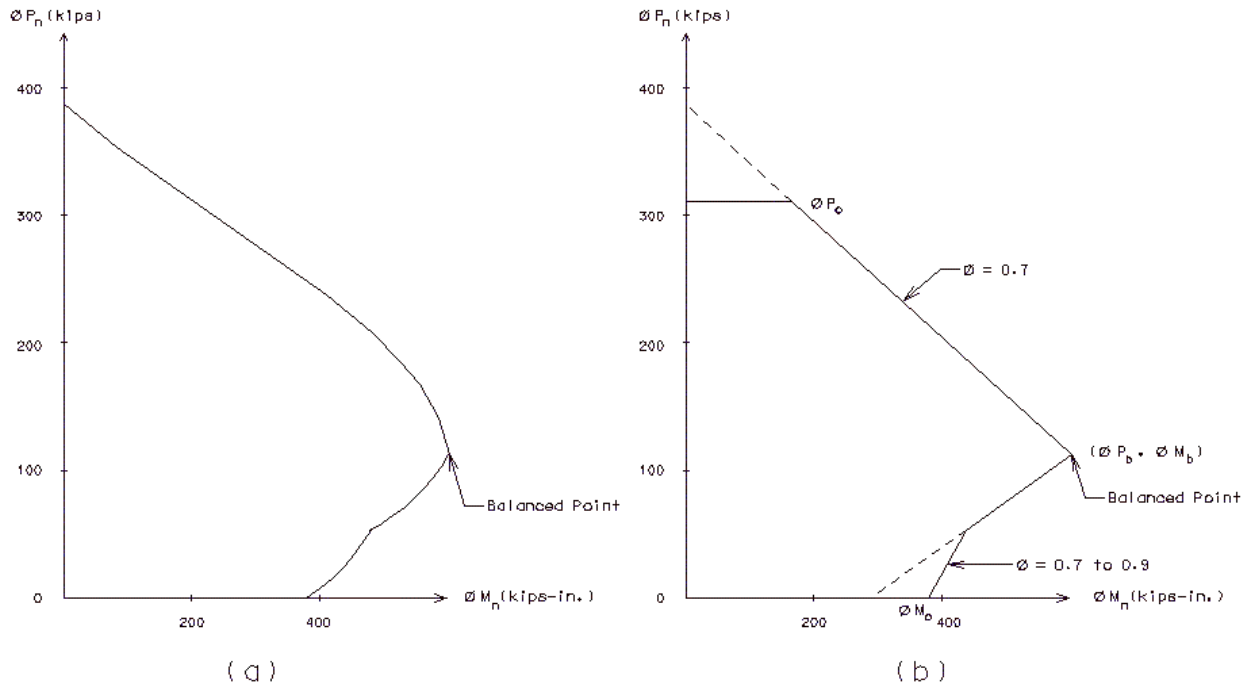

Figure 3.20.2.4-1 (a) Typical interaction diagram (b) simplified interaction diagram

Deflection Control

AASHTO 8.9.2

Minimum slab thickness shall be determined according to Equation (2.4-31). In any case the top and bottom slabs shall not be less than 8”.

$$T_{min} = \frac{(S + 10)}{30} \geq 0.67' \quad \text{Equation (2.4-31)}$$

Where

T_{min} = minimum slab thickness in feet

S = clear span length in feet

Crack Control

AASHTO 17.6.4.7

All concrete members of box culverts except wing walls shall be checked for crack control. Maximum tensile stress at service load in steel reinforcement shall not exceed the allowable stress, f_s .

$$f_s = \frac{155}{\beta(d_c A)^{1/3}} \leq 0.6f_y \quad \text{Equation (2.4-32)}$$

Where

$$\beta = 1 + \frac{d_c}{0.7d}$$

$$A = \frac{2d_c b}{m}$$

f_s = allowable stress at service load in kips per square inch

f_y = minimum yield strength of steel reinforcement in ksi

d_c = distance measured from the tensile concrete surface to the center of the closest bar in inch (For calculation purposes, the thickness of clear concrete cover used to compute d_c shall not be taken greater than 2 inches).

A = effective tension area of concrete per bar in square inch

d = effective depth of a member (Note: thickness of monolithic wearing or protective surface shall be excluded at the compressive face of the member where applicable. See Section 3.20.2.5)

b = width of a section

m = number of tensile reinforcement bars

Fatigue Stress Limit

AASHTO 8.16.8.3

Stress range between maximum and minimum tensile stresses in steel reinforcement caused by live load plus impact at service load shall be computed using Equation (2.4-33). The allowable tensile stress range can be calculated based on Equation (2.4-34). In any case, the stress range shall not exceed the allowable stress range as shown in Equation (2.4-35).

$$f_r = f_{\max} - f_{\min} \qquad \text{Equation (2.4-33)}$$

$$f_f = 21 - 0.33f_{\min} + 8\left(\frac{r}{h}\right) \qquad \text{Equation (2.4-34)}$$

$$f_f \geq f_r \qquad \text{Equation (2.4-35)}$$

Where

f_r = actual stress range at service load in kips per square inch

f_f = allowable stress range in kips per square inch

f_{\max} = algebraic maximum stress level, tension (positive), compressive (negative), in kips per square inch

f_{\min} = algebraic minimum stress level, tension (positive), compressive (negative), in kips per square inch

$r/h = 0.3$

2.5 Criteria for Steel Reinforcement

Steel reinforcement shall be non-epoxy coated bar unless otherwise noted.

Distribution of Reinforcement

AASHTO 3.24.10

Longitudinal distribution reinforcement (parallel with the centerline of structure) at the bottom of the top slab shall be provided to distribute the concentrated live load when the earth fill depth is less than or equal to two feet. The amount of distribution of reinforcement shall be the percentage of main steel reinforcement for positive moment given as following:

AASHTO Equation 3-21

$$\text{Percentage} = \frac{100}{\sqrt{S}} \leq 50\% \qquad \text{Equation (2.5-1)}$$

Where

S = effective span length in feet

Minimum Requirement of Reinforcement

AASHTO 8.17.1.1

(1) Flexural members

Any section of a flexural member shall provide a minimum area of steel reinforcement to develop a moment capacity (i.e., ϕM_n) at least 1.2 times cracking moment:

$$\phi M_n \geq 1.2 M_r \qquad \text{Equation (2.5-2)}$$

Where

ϕ = strength reduction factor for flexure

M_n = nominal moment at a considered section

M_r = cracking moment of a considered section based on rupture modulus calculation

This requirement can be neglected if the area of flexural steel reinforcement, provided at that section, is at least 1/3 greater than that required by the analysis based on the loading combination specified in Section 3.20.2.4.

AASHTO 8.19

A minimum steel area of shear reinforcement in Equation (2.5-4) should be provided in flexural members when factored shear exceeds one-half of shear capacity (i.e., ϕV_n) in Equation (2.5-3).

$$V_u > \frac{1}{2} \phi V_n \qquad \text{Equation (2.5-3)}$$

$$A_v = \frac{50bs}{f_y} \qquad \text{Equation (2.5-4)}$$

Where

V_n = nominal shear capacity provided by concrete section only

ϕ = strength reduction factor for shear

A_v = required steel area of shear reinforcement in in.²

b = width of section in inches

s = spacing of shear reinforcement steel in inches

(2) Compression members

AASHTO 8.18.1.2

The total area of compressive reinforcement should not be less than 1% or greater than 8% of gross area of a section. Compressive reinforcement shall be at least #5 bar.

Reinforcement for Temperature and Shrinkage

AASHTO 8.20

The total area of reinforcement for temperature and shrinkage provided shall be at least 1/8 squared inches per foot in each direction near stream faces. The spacing of steel reinforcement shall not exceed 3 times the wall or slab thickness, or 18".

Spacing Limit of Reinforcement

AASHTO 8.21

Main flexural steel reinforcement in slabs and walls shall be spaced not farther apart than 1.5 times the wall or slab thickness, or 18".

Bridge Manual 2.4.10

Minimum spacing of flexural steel reinforcement in slabs and walls shall not be less than 5" and 4" centers, respectively.

AASHTO 8.19.3

Spacing of shear reinforcement shall not exceed $d/2$ or 24" where d is the effective depth of a section.

The clear distance between parallel bars in a layer shall not be less than larger of 1.5 bar diameters, 1.5 times the maximum size of the coarse aggregate, or 2-1/2" (Bridge Manual 2.4.10). This clear distance limitation shall also apply to the clear distance between a contact lap splice and adjacent splices or bars.

Spacing of steel reinforcement shall be 1/2" increment.

Reinforcement Concrete Cover

AASHTO 8.22

Minimum concrete cover shall be 1-1/2" clearance except the following:

(1) Top slab

Minimum concrete cover shall be 2" and 1-1/2" clearance at top and bottom of the slab, respectively.

(2) Bottom slab

Minimum concrete cover shall be 1-1/2" and 3" clearance at top and bottom of the slab, respectively.

(3) Walls and wing walls

Minimum concrete cover shall be 2" and 1-1/2" clearance at fill and stream faces, respectively.

Wearing Surface

A 1/2" monolithic wearing surface shall be used on stream faces of walls and bottom slab. A 1" monolithic protective surface shall also be used on the bottom of bottom slab to compensate for pouring concrete on uneven earth surfaces. In the analysis, both wearing and protective surfaces are included as part(s) of the member thickness, but they shall be excluded in the calculation of effective depth of the member for design.

Extension of Flexural Reinforcement

AASHTO 8.24

Steel reinforcement should extend beyond a contraflexure point (zero moment location) in accordance with AASHTO 8.24.1.2.1. Alternatively, the extension length of reinforcement, equal to development length l_d , may be used.

Lengths and Sizes of Reinforcement

See Bridge Manual 2.4.10.

Lap Splice of Reinforcement

See Bridge Manual Section 2.4.

Hook Bar

See Bridge Manual Section 2.4.

Development Length of Reinforcement

See Bridge Manual Section 2.4 for a minimum development length l_d .

2.6 Design Example 1: Live Load Analysis Using Influence Line Method

Find factored moments at Section A-A due to live load in a box culvert shown in Figure 3.20.2.6-1(a). Both HS20 and the Military Tandem Axle Loading are considered as live loads in this example. The earth fill depth is 2'-5" from the top of top slab to roadway surface. An impact factor of 10% is used as specified in Section 3.20.2.2. Configurations of one-wheel-line HS20 and Military Tandem Axle Loading are also shown in Figures 3.20.2.6-1(b) and (c), respectively.

Given:

- Compressive strength of concrete, f'_c = 4000 psi
- Minimum yield strength of steel reinf., f_y = 60000 psi
- Top slab thickness, TS = 12.5"
- Bottom slab thickness, BS = 12"
- Exterior wall thickness, TX = 12"
- Interior wall thickness, TI = 12"
- Clear wall height, HT = 12'
- Clear span length, S = 14'

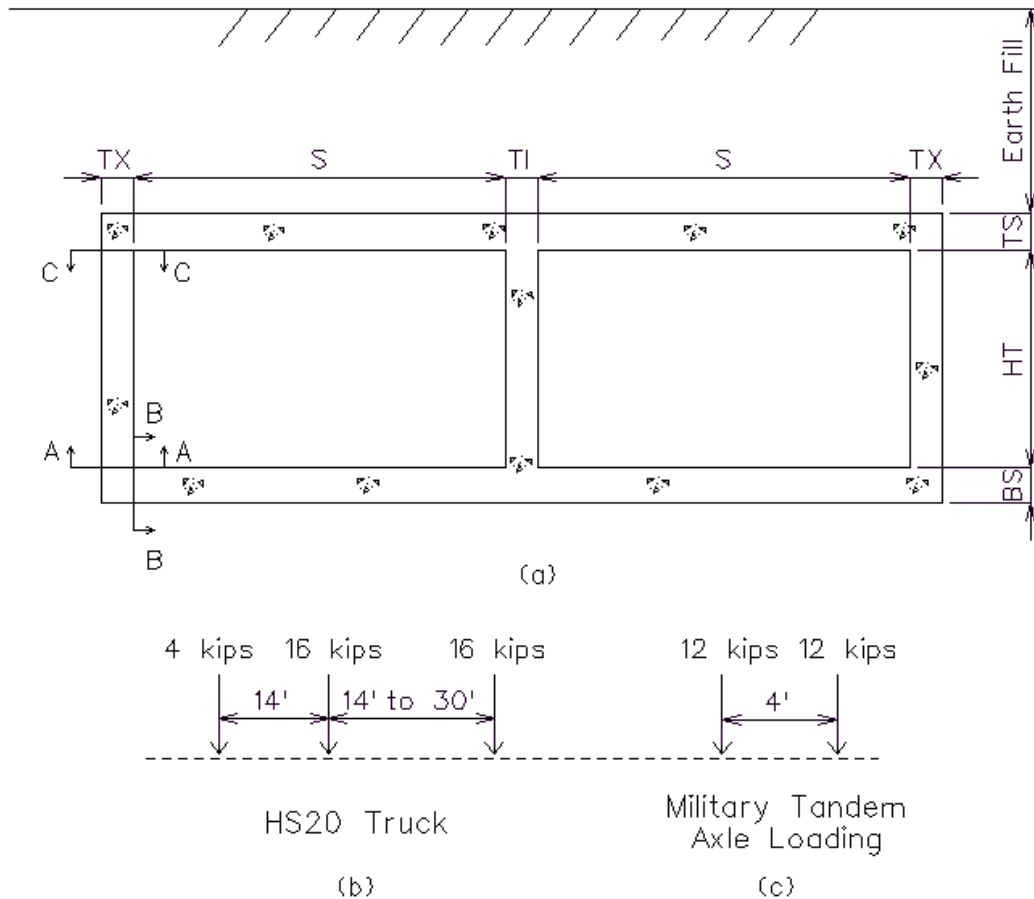

Figure 3.20.2.6-1 Typical cross section of double box culvert (a) dimensions (b) one wheel line of HS20 Truck (c) one wheel line of Military Tandem Axle Loading

Solution:

The structural model and points for generating influence lines for moments are shown in Figure 3.20.2.6-2. As shown in the model, each top slab member consists of 20 points (i.e., number as 100, 105, 110, etc.) where a unit concentrated load will be applied. The influence lines for moments corresponding to 11 points of Member #1 are listed in Table 3.20.2.6-1. One unit concentrated load on the top slab and corresponding uniform load on the bottom slab are used for generating influence lines.

Determine span length and wall height for analysis,

$$\text{Span length, } S' = \frac{TX}{2} + \frac{TI}{2} + S = \frac{1'}{2} + \frac{1'}{2} + 14' = 15'$$

$$\text{Wall height, } L = \frac{TS}{2} + \frac{BS}{2} + HT = \frac{1.0417'}{2} + \frac{1'}{2} + 12' = 13.0208'$$

Since the earth fill depth is 2'-5", which is greater than 2', the live load shall be treated as a uniformly distributed load over a square area on the top slab as described in Section 3.20.2.2.

$$E = 1.75H = 1.75(2.41') = 4.2175' \quad \text{Equation (2.2-2)}$$

Magnitude of uniform load due to HS20 truck,

$$W_{HS20} = \frac{P_{HS20}}{(E)(E)} = \frac{16 \text{ kips}}{(4.2175)^2} = 0.8995 \text{ kips/ft.}^2$$

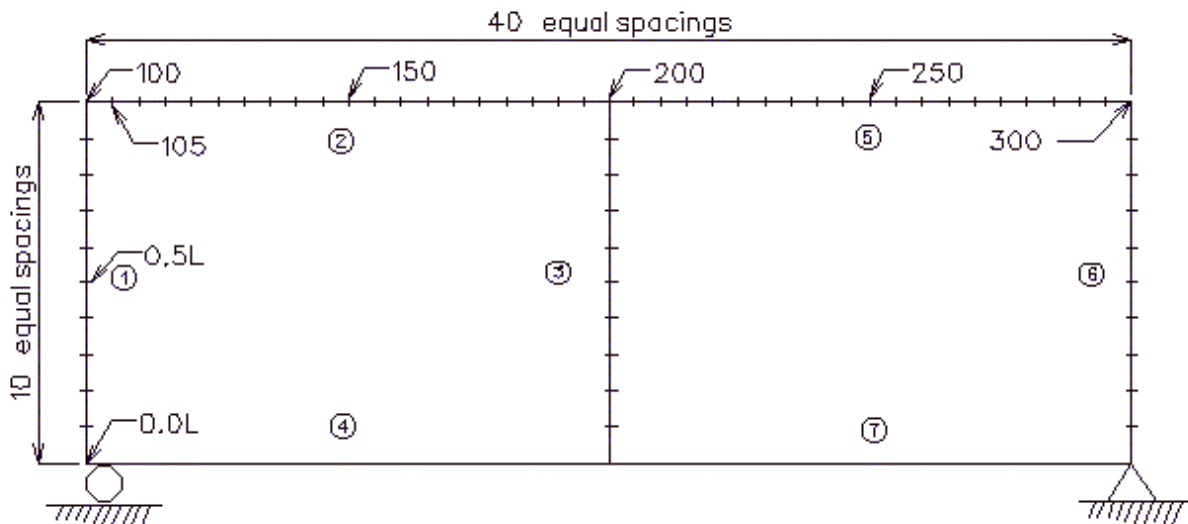

Note: O represents member ID number.

Figure 3.20.2.6-2 Structural model for live load analysis

Table 3.20.2.6-1 Influence lines for moments of Member #1

Point Number	Influence Lines at 1/10 pt. Of Member #1										
	0.0L	0.1L	0.2L	0.3L	0.4L	0.5L	0.6L	0.7L	0.8L	0.9L	1.0L
100	-1.17	-0.96	-0.74	-0.52	-0.31	-0.09	0.13	0.34	0.56	0.78	0.99
105	-1.09	-0.91	-0.74	-0.57	-0.39	-0.22	-0.04	0.13	0.3	0.48	0.65
110	-0.99	-0.86	-0.72	-0.59	-0.46	-0.32	-0.19	-0.06	0.08	0.21	0.34
115	-0.88	-0.79	-0.69	-0.6	-0.5	-0.41	-0.31	-0.21	-0.12	-0.02	0.07
120	-0.78	-0.71	-0.65	-0.59	-0.53	-0.47	-0.41	-0.35	-0.29	-0.23	-0.16
125	-0.66	-0.63	-0.6	-0.57	-0.55	-0.52	-0.49	-0.46	-0.43	-0.4	-0.37
130	-0.55	-0.55	-0.55	-0.55	-0.55	-0.55	-0.55	-0.55	-0.55	-0.54	-0.54
135	-0.43	-0.46	-0.48	-0.51	-0.53	-0.56	-0.59	-0.61	-0.64	-0.66	-0.69
140	-0.32	-0.37	-0.41	-0.46	-0.51	-0.56	-0.61	-0.66	-0.71	-0.76	-0.81
145	-0.2	-0.27	-0.34	-0.41	-0.48	-0.55	-0.62	-0.69	-0.76	-0.83	-0.9
150	-0.1	-0.18	-0.27	-0.36	-0.45	-0.53	-0.62	-0.71	-0.8	-0.88	-0.97
155	0.01	-0.1	-0.2	-0.3	-0.4	-0.51	-0.61	-0.71	-0.81	-0.91	-1.02
160	0.1	-0.01	-0.13	-0.24	-0.36	-0.47	-0.58	-0.7	-0.81	-0.93	-1.04
165	0.19	0.06	-0.06	-0.18	-0.31	-0.43	-0.55	-0.68	-0.8	-0.92	-1.05
170	0.26	0.13	0	-0.13	-0.26	-0.39	-0.52	-0.65	-0.78	-0.91	-1.04
175	0.33	0.19	0.06	-0.07	-0.21	-0.34	-0.47	-0.61	-0.74	-0.87	-1.01
180	0.38	0.24	0.11	-0.03	-0.16	-0.29	-0.43	-0.56	-0.69	-0.83	-0.96
185	0.41	0.28	0.15	0.02	-0.12	-0.25	-0.38	-0.51	-0.64	-0.77	-0.91
190	0.43	0.3	0.18	0.05	-0.08	-0.2	-0.33	-0.46	-0.58	-0.71	-0.84
195	0.43	0.31	0.19	0.07	-0.05	-0.17	-0.28	-0.4	-0.52	-0.64	-0.76
200	0.41	0.3	0.19	0.08	-0.02	-0.13	-0.24	-0.35	-0.45	-0.56	-0.67
205	0.37	0.28	0.18	0.09	-0.01	-0.1	-0.2	-0.29	-0.39	-0.48	-0.58
210	0.33	0.25	0.16	0.08	0	-0.08	-0.16	-0.24	-0.33	-0.41	-0.49
215	0.28	0.21	0.14	0.08	0.01	-0.06	-0.13	-0.2	-0.27	-0.34	-0.4
220	0.23	0.17	0.12	0.06	0.01	-0.05	-0.1	-0.16	-0.21	-0.27	-0.32
225	0.17	0.13	0.09	0.05	0.01	-0.03	-0.08	-0.12	-0.16	-0.2	-0.24
230	0.1	0.08	0.05	0.03	0	-0.03	-0.05	-0.08	-0.1	-0.13	-0.16
235	0.03	0.02	0.01	0	-0.01	-0.02	-0.03	-0.04	-0.05	-0.06	-0.08
240	-0.04	-0.04	-0.03	-0.03	-0.02	-0.02	-0.01	-0.01	0	0	0
245	-0.12	-0.1	-0.08	-0.06	-0.04	-0.02	0	0.02	0.04	0.06	0.08
250	-0.2	-0.16	-0.13	-0.09	-0.06	-0.02	0.02	0.05	0.09	0.13	0.16
255	-0.29	-0.23	-0.18	-0.13	-0.08	-0.02	0.03	0.08	0.13	0.19	0.24
260	-0.38	-0.31	-0.24	-0.17	-0.1	-0.03	0.04	0.11	0.18	0.25	0.32
265	-0.47	-0.38	-0.3	-0.21	-0.12	-0.04	0.05	0.14	0.23	0.31	0.4
270	-0.56	-0.46	-0.36	-0.25	-0.15	-0.04	0.06	0.17	0.27	0.37	0.48
275	-0.66	-0.54	-0.42	-0.3	-0.17	-0.05	0.07	0.19	0.32	0.44	0.56
280	-0.76	-0.62	-0.48	-0.34	-0.2	-0.06	0.08	0.22	0.36	0.5	0.64
285	-0.86	-0.71	-0.55	-0.39	-0.23	-0.07	0.09	0.25	0.41	0.57	0.73
290	-0.97	-0.79	-0.61	-0.43	-0.26	-0.08	0.1	0.28	0.46	0.63	0.81
295	-1.07	-0.88	-0.68	-0.48	-0.28	-0.09	0.11	0.31	0.5	0.7	0.9
300	-1.18	-0.96	-0.75	-0.53	-0.31	-0.09	0.12	0.34	0.56	0.77	0.99

Note: "L" is the height of wall member.

Magnitude of uniform load due to Military Tandem Axle Loading,

$$W_{Military} = \frac{P_{Military}}{(E)(E)} = \frac{12 \text{ kips}}{(4.2175)^2} = 0.6746 \text{ kips/ft.}^2$$

Determine a number of points from the influence line table that should be used to represent the uniform load.

$$N = \frac{E}{X} + 1 = \frac{4.2175'}{0.75'} + 1 \cong 7 \text{ points within the distributed width, } E$$

Where X is the length between two points (i.e., $X = \frac{\text{Span length}}{21 \text{ points} - 1} = \frac{15'}{20} = 0.75'$).

Therefore, the equivalent concentrated load at each point can be estimated as following:

$$\frac{W(E)}{N} = \frac{0.8995(4.2175)}{7} = 0.5419 \text{ kip/point for HS20 truck}$$

$$\frac{W(E)}{N} = \frac{0.6746(4.2175)}{7} = 0.4064 \text{ kip/point for Military Tandem Axle Loading}$$

From Table 3.20.2.6-1, the moments at 0.0L of Member #1 due to unit loads applied at individual points on the top slab are shown in Table 3.20.2.6-2. There are total of 41 points of unit loads to be applied; however, only 11 points are shown in the table. Total moments at 0.0L of Member #1 due to uniform distributed load with magnitude equal to a unit are also shown at the bottom of the table.

Table 3.20.2.6-3 summarizes the total moment at 0.0L and 0.1L of Member #1 due to unit loads distributed at individual points on the top slab. The corresponding equivalent concentrated loads at individual point on the top slab are also shown in the table. It shows that the equivalent concentrated loads increase as the end of the span is reached. This is because, for example, when a 16 kip load is centered at point 300, all of the seven points are not on the span (i.e., only 4 points on the span). Therefore, the equivalent concentrated load can be calculated conservatively as:

$$\frac{W(E)}{\#N} = \frac{0.8995(4.2175)}{4} = 0.9484 \text{ kip}$$

Where #N is a number of points that wheel load distributes on the span.

For a typical wheel line arrangement, the live load moment, M_L , of Member #1 at section 0.0L or 0.1L can then be calculated as:

$M_L = (\text{impact factor})(\text{summation of moments due to each wheel load location on the top slab})$

For example, The first and second wheel loads (i.e., about 14' apart) are at points 100 and 195, respectively. Then, the summation of moments at 0.1L of Member #1 due to the first wheel load (from Table 3.20.2.6-3) is equal to:

$$(-3.52)(0.9484) = -3.34 \text{ kips-ft.}$$

The summation of moments at 0.1L of Member #1 due to the second wheel load (from Table 3.20.2.6-3) is equal to:

$$(1.96)(0.5419) = 1.06 \text{ kips-ft.}$$

Therefore, $M_L = (1.10 \text{ impact})(-3.34 + 1.06) = -2.51 \text{ kips-ft.}$

Tables 3.20.2.6-4 and 3.20.2.6-5 summarize the live load moments of Member #1 at sections 0.0L and 0.1L due to all the possibilities of wheel load locations, respectively. It can be seen that the maximum live load moments at 0.0L and 0.1L are -8.57 kips-ft. and -7.16 kips-ft., respectively, occurred when the first wheel load is at point 100 and the second wheel load is at point 300 (i.e., 30' apart).

Similarly, the same procedure was performed for the Military Tandem Axle Loading. The equivalent concentrated loads and moments for this loading are shown in Table 3.20.2.6-6. Live load moments of Member #1 at section 0.0L and 0.1L are listed in Tables 3.20.2.6-7 and 3.20.2.6-8, respectively. At section 0.0L, it shows that maximum live load moment of -4.97 kips-ft occurred when the first and second wheel loads are at points 265 and 295, respectively. At section 0.1L, it also shows that the maximum live load moment of -4.44 kips-ft occurred when the first and second wheel loads are at points 100 and 130, respectively.

Live load moments resulted from HS20 loading are larger than those caused by the Military Tandem Axle Loading. Therefore, the maximum live loads at sections 0.0L and 0.1L are controlled by HS20 truck. Live load moment at Section A-A, which is 0.5' from 0.0L, can be obtained by linear interpolation of moments between 0.0L and 0.1L.

$$x = 0.1L = 0.1(13.021') = 1.3021'$$

$$y = \text{half of slab thickness} = 12''/2 = 6'' = 0.5'$$

$$\frac{M_{LL@A-A} - M_{LL@0.1L}}{x - y} = \frac{M_{LL@0.0L} - M_{LL@0.1L}}{x}$$

$$\frac{M_{LL@A-A} - (-7.16)}{1.3021 - 0.5} = \frac{-8.57 - (-7.16)}{1.3021}$$

Thus, $M_{LL@A-A} = -8.03 \text{ kips-ft.}$

Table 3.20.2.6-2 Sample calculation of moments at 0.0L of Member #1 due to unit loads

Point Number	Moments at 0.0L Due to Unit Loads										
	100	105	110	115	120	125	130	135	140	145	150
100	-1.17	-1.17	-1.17	-1.17							
105	-1.09	-1.09	-1.09	-1.09	-1.09						
110	-0.99	-0.99	-0.99	-0.99	-0.99	-0.99					
115	-0.88	-0.88	-0.88	-0.88	-0.88	-0.88	-0.88				
120		-0.78	-0.78	-0.78	-0.78	-0.78	-0.78	-0.78			
125			-0.66	-0.66	-0.66	-0.66	-0.66	-0.66	-0.66		
130				-0.55	-0.55	-0.55	-0.55	-0.55	-0.55	-0.55	
135					-0.43	-0.43	-0.43	-0.43	-0.43	-0.43	-0.43
140						-0.32	-0.32	-0.32	-0.32	-0.32	-0.32
145							-0.2	-0.2	-0.2	-0.2	-0.2
150								-0.1	-0.1	-0.1	-0.1
155									0.01	0.01	0.01
160										0.1	0.1
165											0.19
170											
175											
180											
185											
190											
195											
200											
205											
210											
215											
220											
225											
230											
235											
240											
245											
250											
255											
260											
265											
270											
275											
280											
285											
290											
295											
300											
Total	-4.13	-4.91	-5.57	-6.12	-5.38	-4.61	-3.82	-3.04	-2.25	-1.49	-0.75

Table 3.20.2.6-3 Moments and equivalent concentrated loads for HS20 loading at 0.0L and 0.1L of Member #1

Point Number	HS20 LOADING		HS20 LOADING	
	Moment @ 0.0L	Equiv. Conc. Load	Moment @ 0.1L	Equiv. Conc. Load
100	-4.13	0.9484	-3.52	0.9484
105	-4.91	0.7587	-4.23	0.7587
110	-5.57	0.6323	-4.86	0.6323
115	-6.12	0.5419	-5.41	0.5419
120	-5.38	0.5419	-4.91	0.5419
125	-4.61	0.5419	-4.37	0.5419
130	-3.82	0.5419	-3.78	0.5419
135	-3.04	0.5419	-3.17	0.5419
140	-2.25	0.5419	-2.56	0.5419
145	-1.49	0.5419	-1.94	0.5419
150	-0.75	0.5419	-1.33	0.5419
155	-0.06	0.5419	-0.74	0.5419
160	0.59	0.5419	-0.18	0.5419
165	1.17	0.5419	0.33	0.5419
170	1.68	0.5419	0.79	0.5419
175	2.10	0.5419	1.19	0.5419
180	2.43	0.5419	1.51	0.5419
185	2.61	0.5419	1.75	0.5419
190	2.76	0.5419	1.90	0.5419
195	2.76	0.5419	1.96	0.5419
200	2.66	0.5419	1.93	0.5419
205	2.48	0.5419	1.82	0.5419
210	2.22	0.5419	1.65	0.5419
215	1.89	0.5419	1.42	0.5419
220	1.51	0.5419	1.14	0.5419
225	1.10	0.5419	0.82	0.5419
230	0.65	0.5419	0.47	0.5419
235	0.17	0.5419	0.10	0.5419
240	-0.35	0.5419	-0.30	0.5419
245	-0.90	0.5419	-0.74	0.5419
250	-1.47	0.5419	-1.20	0.5419
255	-2.06	0.5419	-1.68	0.5419
260	-2.68	0.5419	-2.18	0.5419
265	-3.32	0.5419	-2.70	0.5419
270	-3.98	0.5419	-3.25	0.5419
275	-4.66	0.5419	-3.81	0.5419
280	-5.35	0.5419	-4.38	0.5419
285	-6.06	0.5419	-0.96	0.5419
290	-5.50	0.6323	-4.50	0.6323
295	-4.84	0.7587	-3.96	0.7587
300	-4.08	0.9484	-3.34	0.9484

Table 3.20.2.6-4 Live load moments of Member #1 at 0.0L for HS20 loading

MAXIMUM LIVE LOAD MOMENT FOR 0.0L (HS20)

		FIRST 16 K WHEEL LOCATION										
Point#		100	105	110	115	120	125	130	135	140	145	150
SECOND 16 K WHEEL LOCATION	195	-2.66										
	200	-2.72	-2.51									
	205	-2.83	-2.62	-2.40								
	210	-2.99	-2.77	-2.55	-2.32							
	215	-3.18	-2.97	-2.75	-2.52	-2.08						
	220	-3.41	-3.20	-2.97	-2.75	-2.31	-1.848					
	225	-3.65	-3.44	-3.22	-2.99	-2.55	-2.09	-1.62				
	230	-3.92	-3.71	-3.49	-3.26	-2.82	-2.36	-1.89	-1.42			
	235	-4.21	-4.00	-3.77	-3.55	-3.11	-2.65	-2.18	-1.71	-1.24		
	240	-4.52	-4.31	-4.08	-3.86	-3.42	-2.96	-2.49	-2.02	-1.55	-1.10	
	245	-4.85	-4.63	-4.41	-4.18	-3.74	-3.28	-2.81	-2.35	-1.88	-1.42	-0.98
	250	-5.18	-4.97	-4.75	-4.52	-4.08	-3.62	-3.15	-2.69	-2.22	-1.76	-1.32
	255	-5.54	-5.33	-5.10	-4.88	-4.43	-3.98	-3.51	-3.04	-2.57	-2.12	-1.68
	260	-5.91	-5.70	-5.47	-5.25	-4.80	-4.35	-3.87	-3.41	-2.94	-2.49	-2.04
	265	-6.29	-6.08	-5.85	-5.63	-5.19	-4.73	-4.26	-3.79	-3.32	-2.87	-2.43
	270	-6.68	-6.47	-6.25	-6.02	-5.58	-5.12	-4.65	-4.18	-3.71	-3.26	-2.82
	275	-7.09	-6.88	-6.65	-6.43	-5.98	-5.53	-5.05	-4.59	-4.12	-3.67	-3.22
	280	-7.50	-7.29	-7.06	-6.84	-6.40	-5.94	-5.47	-5.00	-4.53	-4.08	-3.64
	285	-7.92	-7.71	-7.49	-7.26	-6.82	-6.36	-5.89	-5.42	-4.95	-4.50	-4.06
	290	-8.13	-7.92	-7.70	-7.47	-7.03	-6.57	-6.10	-5.64	-5.17	-4.71	-4.27
295	-8.35	-8.14	-7.91	-7.69	-7.25	-6.79	-6.32	-5.85	-5.38	-4.93	-4.49	
300	-8.57	-8.35	-8.13	-7.90	-7.46	-7.00	-6.53	-6.07	-5.60	-5.14	-4.70	

MAXIMUM LIVE LOAD MOMENT FOR 0.0L (HS20) continue

		FIRST 16 K WHEEL LOCATION										
Point#		155	160	165	170	175	180	185	190	195	200	205
SECOND 16 K WHEEL LOCATION	195											
	200											
	205											
	210											
	215											
	220											
	225											
	230											
	235											
	240											
	245											
	250	-0.91										
	255	-1.26	-0.94									
	260	-1.63	-1.31	-0.90								
	265	-2.01	-1.69	-1.28	-0.98							
	270	-2.41	-2.08	-1.68	-1.37	-1.12						
	275	-2.81	-2.49	-2.08	-1.78	-1.53	-1.33					
	280	-3.22	-2.90	-2.49	-2.19	-1.94	-1.74	-1.63				
	285	-3.65	-3.32	-2.91	-2.61	-2.36	-2.16	-2.06	-1.97			
	290	-3.86	-3.53	-3.13	-2.82	-2.57	-2.38	-2.27	-2.18	-2.18		
295	-4.08	-3.75	-3.34	-3.04	-2.79	-2.59	-2.48	-2.39	-2.39	-2.45		
300	-4.29	-3.96	-3.56	-3.25	-3.00	-2.81	-2.70	-2.61	-2.61	-2.67	-2.78	

Table 3.20.2.6-5 Live load moments of Member #1 at 0.1L for HS20 loading

MAXIMUM LIVE LOAD MOMENT FOR 0.1L (HS20)

		FIRST 16 K WHEEL LOCATION										
Point#		100	105	110	115	120	125	130	135	140	145	150
SECOND 16 K WHEEL LOCATION	195	-2.50										
	200	-2.52	-2.38									
	205	-2.59	-2.45	-2.30								
	210	-2.69	-2.55	-2.40	-2.24							
	215	-2.83	-2.68	-2.53	-2.38	-2.12						
	220	-2.99	-2.85	-2.70	-2.55	-2.29	-1.93					
	225	-3.18	-3.04	-2.89	-2.74	-2.48	-2.12	-1.76				
	230	-3.39	-3.25	-3.10	-2.94	-2.69	-2.32	-1.97	-1.61			
	235	-3.61	-3.47	-3.32	-3.17	-2.91	-2.55	-2.19	-1.83	-1.47		
	240	-3.85	-3.71	-3.56	-3.40	-3.14	-2.78	-2.43	-2.07	-1.70	-1.34	
	245	-4.11	-3.97	-3.82	-3.67	-3.41	-3.05	-2.69	-2.33	-1.97	-1.60	-1.23
	250	-4.39	-4.25	-4.10	-3.94	-3.68	-3.32	-2.97	-2.60	-2.24	-1.87	-1.51
	255	-4.67	-4.53	-4.38	-4.23	-3.97	-3.61	-3.25	-2.89	-2.53	-2.16	-1.79
	260	-4.97	-4.83	-4.68	-4.52	-4.27	-3.90	-3.55	-3.19	-2.83	-2.46	-2.09
	265	-5.28	-5.14	-4.99	-4.83	-4.58	-4.21	-3.86	-3.50	-3.14	-2.77	-2.40
	270	-5.61	-5.47	-5.32	-5.16	-4.90	-4.54	-4.19	-3.83	-3.46	-3.09	-2.73
	275	-5.94	-5.80	-5.65	-5.50	-5.24	-4.88	-4.52	-4.16	-3.80	-3.43	-3.06
	280	-6.28	-6.14	-5.99	-5.84	-5.58	-5.22	-4.86	-4.50	-4.14	-3.77	-3.40
	285	-4.24	-4.10	-3.95	-3.80	-3.54	-3.18	-2.83	-2.46	-2.10	-1.73	-1.37
	290	-6.80	-6.66	-6.51	-6.35	-6.10	-5.73	-5.38	-5.02	-4.66	-4.29	-3.92
295	-6.98	-6.84	-6.69	-6.53	-6.27	-5.91	-5.56	-5.19	-4.83	-4.46	-4.10	
300	-7.16	-7.01	-6.86	-6.71	-6.45	-6.09	-5.74	-5.37	-5.01	-4.64	-4.28	

MAXIMUM LIVE LOAD MOMENT FOR 0.1L (HS20) continue

		FIRST 16 K WHEEL LOCATION										
Point#		155	160	165	170	175	180	185	190	195	200	205
SECOND 16 K WHEEL LOCATION	195											
	200											
	205											
	210											
	215											
	220											
	225											
	230											
	235											
	240											
	245											
	250	-1.16										
	255	-1.44	-1.11									
	260	-1.74	-1.41	-1.10								
	265	-2.05	-1.72	-1.41	-1.14							
	270	-2.38	-2.04	-1.74	-1.47	-1.23						
	275	-2.71	-2.38	-2.07	-1.80	-1.56	-1.37					
	280	-3.05	-2.72	-2.41	-2.14	-1.90	-1.71	-1.57				
	285	-1.01	-0.68	-0.38	-0.10	0.14	0.33	0.47	0.56			
	290	-3.57	-3.24	-2.93	-2.66	-2.42	-2.23	-2.09	-2.00	-1.96		
295	-3.75	-3.41	-3.11	-2.83	-2.60	-2.40	-2.26	-2.17	-2.14	-2.15		
300	-3.93	-3.59	-3.29	-3.01	-2.78	-2.58	-2.44	-2.35	-2.32	-2.33	-2.40	

Table 3.20.2.6-6 Moments and equivalent concentrated loads for the Military Tandem Axle Loading at 0.0L and 0.1L of Member #1

Point Number	MILITARY LOADING		MILITARY LOADING	
	Moment @ 0.0L	Equiv. Conc. Load	Moment @ 0.1L	Equiv. Conc. Load
100	-4.13	0.7113	-3.52	0.7113
105	-4.91	0.5691	-4.23	0.5691
110	-5.57	0.4742	-4.86	0.4742
115	-6.12	0.4064	-5.41	0.4064
120	-5.38	0.4064	-4.91	0.4064
125	-4.61	0.4064	-4.37	0.4064
130	-3.82	0.4064	-3.78	0.4064
135	-3.04	0.4064	-3.17	0.4064
140	-2.25	0.4064	-2.56	0.4064
145	-1.49	0.4064	-1.94	0.4064
150	-0.75	0.4064	-1.33	0.4064
155	-0.06	0.4064	-0.74	0.4064
160	0.59	0.4064	-0.18	0.4064
165	1.17	0.4064	0.33	0.4064
170	1.68	0.4064	0.79	0.4064
175	2.10	0.4064	1.19	0.4064
180	2.43	0.4064	1.51	0.4064
185	2.61	0.4064	1.75	0.4064
190	2.76	0.4064	1.90	0.4064
195	2.76	0.4064	1.96	0.4064
200	2.66	0.4064	1.93	0.4064
205	2.48	0.4064	1.82	0.4064
210	2.22	0.4064	1.65	0.4064
215	1.89	0.4064	1.42	0.4064
220	1.51	0.4064	1.14	0.4064
225	1.10	0.4064	0.82	0.4064
230	0.65	0.4064	0.47	0.4064
235	0.17	0.4064	0.10	0.4064
240	-0.35	0.4064	-0.30	0.4064
245	-0.90	0.4064	-0.74	0.4064
250	-1.47	0.4064	-1.20	0.4064
255	-2.06	0.4064	-1.68	0.4064
260	-2.68	0.4064	-2.18	0.4064
265	-3.32	0.4064	-2.70	0.4064
270	-3.98	0.4064	-3.25	0.4064
275	-4.66	0.4064	-3.81	0.4064
280	-5.35	0.4064	-4.38	0.4064
285	-6.06	0.4064	-0.96	0.4064
290	-5.50	0.4742	-4.50	0.4742
295	-4.84	0.5691	-3.96	0.5691
300	-4.08	0.7113	-3.34	0.7113

Table 3.20.2.6-7 Live load moments of Member #1 at 0.0L for the Military Tandem Axle Loading

MAXIMUM LIVE LOAD MOMENT FOR 0.0 L (MILITARY)

Point #	100	105	110	115	120	125	130	135	140	145	150	155	160	165	170	175	180	185	
130	-4.94																		
135		-4.43																	
140			-3.91																
145				-3.40															
150					-2.74														
155						-2.09													
160							-1.44												
165								-0.84											
170									-0.25										
175										0.27									
180											0.75								
185												1.14							
190													1.50						
195														1.76					
200															1.94				
205																2.05			
210																	2.08		
215																		2.01	
220																			
225																			
230																			
235																			
240																			
245																			
250																			
255																			
260																			
265																			
270																			
275																			
280																			
285																			
290																			
295																			
300																			

MAXIMUM LIVE LOAD MOMENT FOR 0.0 L (MILITARY) continue

Point #	190	195	200	205	210	215	220	225	230	235	240	245	250	255	260	265	270
130																	
135																	
140																	
145																	
150																	
155																	
160																	
165																	
170																	
175																	
180																	
185																	
190																	
195																	
200																	
205																	
210																	
215																	
220	1.91																
225		1.73															
230			1.48														
235				1.18													
240					0.84												
245						0.44											
250							0.02										
255								-0.81									
260									-1.41								
265										-1.94							
270											-2.48						
275												-3.05					
280													-3.63				
285														-4.07			
290															-4.51		
295																-4.97	
300																	-2.08

Table 3.20.2.6-8 Live load moments of Member #1 at 0.1L for the Military Tandem Axle Loading

MAXIMUM LIVE LOAD MOMENT FOR 0.1 L (MILITARY)
FIRST 12 K WHEEL LOCATION

Point #	100	105	110	115	120	125	130	135	140	145	150	155	160	165	170	175	180	185	
130	-4.44																		
135																			
140		-4.07																	
145			-3.68																
150				-3.29															
155					-2.79														
160						-2.28													
165							-1.77												
170								-1.27											
175									-0.79										
180										-0.34									
185											0.08								
190												0.45							
195													0.77						
200														1.02					
205															1.22				
210																1.35			
215																	1.41		
220																		1.42	
225																			
230																			
235																			
240																			
245																			
250																			
255																			
260																			
265																			
270																			
275																			
280																			
285																			
290																			
295																			
300																			

MAXIMUM LIVE LOAD MOMENT FOR 0.1 L (MILITARY) continue
FIRST 12 K WHEEL LOCATION

Point #	190	195	200	205	210	215	220	225	230	235	240	245	250	255	260	265	270
130																	
135																	
140																	
145																	
150																	
155																	
160																	
165																	
170																	
175																	
180																	
185																	
190																	
195																	
200																	
205																	
210																	
215																	
220	1.36																
225		1.24															
230			1.07														
235				0.86													
240					0.60												
245						0.30											
250							-0.03										
255								-0.38									
260									-0.76								
265										-1.16							
270											-1.59						
275												-2.03					
280													-2.49				
285														-1.18			
290															-2.35		
295																-3.69	
300																	-4.07

2.7 Design Example 2: Steel Reinforcement Design for J4 bar

Design J4 reinforcement bar in Member #1 based on factored moment, axial load, and shear at the critical Section A-A as shown in Figure 3.20.2.6-1(a) in Example 1. Assume #5 B2 bars spacing at 11.5”.

Given:

Compressive strength of concrete, f'_c	= 4000 psi
Minimum yield strength of steel reinforcement, f_y	= 60000 psi
Moment due to dead loads, M_d	= -5.29 kips-feet (at point 0.0L of Member #1) = -4.95 kips-feet (at point 0.1L of Member #1)
Moment due to horizontal soil pressures, M_s	= -6.33 kips-feet (at point 0.0L of Member #1) = -0.285 kips-feet (at point 0.1L of Member #1)
Moment due to horizontal water pressure, M_w	= 3.51 kips-feet (at point 0.0L of Member #1) = -0.129 kips-feet (at point 0.1L of Member #1)
Moment due to live load, M_l	= -8.57 kips-feet (at point 0.0L of Member #1) = -7.16 kips-feet (at point 0.1L of Member #1)
Maximum factored axial force, P_u	= 10.69 kips (in Member #1)
Maximum factored shear force, V_u	= 7.50 kips (taken at a distance “d” from Section A-A)
Maximum factored moment, $M_u @ B-B$	= -26.5 kips-feet (at Section B-B in Member #4)
Maximum factored moment, $M_u @ C-C$	= -21.1 kips-feet (at Section C-C in Member #1)

Where L is wall height and equal to 13.021’. Negative moments shown above indicate tension at fill face of the wall. Positive moments represent tension at stream face of the wall.

Solution:

- 1) Check minimum slab thickness:

$$\begin{aligned} \text{Minimum slab thickness, } T_{\min} &= \frac{(S + 10)}{30} \geq 0.67' && \text{Equation (2.4-31)} \\ &= \frac{(14' + 10)}{30} = 0.8' > 0.67' && \text{O.K.} \end{aligned}$$

Top slab thickness, TS = 12.5” = 1.042’	> T_{\min} O.K.
Bottom slab thickness, BS = 12.0” = 1.00’	> T_{\min} O.K.

- 2) Determine factored moment at Section A-A:

First, calculate the factored moments, M_u , at locations 0.0L and 0.1L

$$M_u = 1.3 [M_d + M_s + M_w + 1.67M_l] \quad \text{Equation (2.4-1)}$$

At Section 0.0L,
 $M_u = 1.3[-5.29 + (-6.33) + 3.51 + 1.67(-8.57)] = -29.15$ kips-ft.

At Section 0.1L,
 $M_u = 1.3[-4.95 + (-0.285) + (-0.129) + 1.67(-7.16)] = -22.52$ kips-ft.

Then, calculate M_u at Section A-A by linear interpolation.
 $x = 0.1L = 0.1(13.021') = 1.3021'$
 $y = \frac{1}{2}$ of member 4 thickness = $12''/2 = 6'' = 0.5'$

$$\frac{M_{u@A-A} - M_{u@0.1L}}{x - y} = \frac{M_{u@0.0L} - M_{u@0.1L}}{x}$$

$$\frac{M_{u@A-A} - (-22.52)}{1.3021 - 0.5} = \frac{-29.15 - (-22.52)}{1.3021} \quad \Rightarrow \therefore M_{u@A-A} = -26.60 \text{ kips-ft.}$$

- 3) Design J4 bar:
 For J4 bar in Member #1 (exterior wall),
 Try #6 for J4 bar.

Effective depth, $d = 12''$ thk. - 2"cover - $\frac{1}{2}$ bar dia. - $\frac{1}{2}''$ wearing surf.
 $= 12''$ thk. - 2"cover - $\frac{1}{2}$ (0.75") - $\frac{1}{2}''$ wearing surf.
 $= 9.125''$

$$R_u = \frac{M_{u@A-A}}{\phi b d^2} = \frac{(26.60)(1000)(12'')}{0.9(12'')(9.125'')^2} = 354.96 \text{ psi} \quad \text{Equation (2.4-7)}$$

$$\rho = \frac{0.85 f_c'}{f_y} \left[1 - \sqrt{1 - \frac{2R_u}{0.85 f_c'}} \right] = 0.00626 \quad \text{Equation (2.4-6)}$$

$$\rho_b = \frac{0.85 \beta_1 f_c'}{f_y} \left(\frac{87000}{87000 + f_y} \right) = 2.8507 \times 10^{-2} \quad \text{Equation (2.4-9)}$$

$$\rho_{\max} = 0.75(\rho_b) = 2.1380 \times 10^{-2} \quad \text{Equation (2.4-8)}$$

$h = TX = 12.0''$

$$\rho_{\min} = 1.7 \left(\frac{h}{d} \right)^2 \frac{\sqrt{f_c'}}{f_y} = 3.0990 \times 10^{-3} \quad \text{Equation (2.4-10)}$$

Since $\rho_{\min} < \rho < \rho_{\max}$, then

$$\text{Steel area required, } A_s = \rho b d = (0.00626)(12'')(9.125'') = 0.69 \text{ in.}^2/\text{ft.} \quad \dots\dots(1)$$

For J4 bar in Member #4 (bottom slab),
 Effective depth, $d = 12''$ thk. - 3"cover - $\frac{1}{2}$ bar dia. - $\frac{1}{2}''$ wearing surf.
 $= 8.125''$

$$R_u = \frac{M_{u@B-B}}{\phi b d^2} = \frac{26.5(1000)(12'')}{0.9(12'')(8.125'')^2} = 446.02 \text{ psi}$$

$$\rho = \frac{0.85 f_c'}{f_y} \left[1 - \sqrt{1 - \frac{2R_u}{0.85 f_c'}} \right] = 0.008$$

$h = BS = 12''$

$$\rho_{\min} = 1.7 \left(\frac{h}{d} \right)^2 \frac{\sqrt{f'_c}}{f_y} = 3.9088 \times 10^{-3}$$

Since $\rho_{\min} < \rho < \rho_{\max}$, then

Steel area required, $A_s = \rho bd = (0.008)(12'')(8.125'') = 0.78 \text{ in.}^2/\text{ft.} \dots\dots(2)$

Choose larger A_s of (1) and (2) above, $\therefore A_s = 0.78 \text{ in.}^2/\text{ft.} \dots\dots\text{Controls.}$

Use #6 bar spacing at 6-1/2" centers ($A_s = 0.816 \text{ in.}^2$)

- 4) Check shear capacity at critical Section A-A in Member #1:
Use Equation (2.4-15) since the earth fill depth of 2'-5" is greater than 2'-0".

$$V_c = \left(2.14\sqrt{f'_c} + 4600\rho \frac{V_u d}{M_u} \right) bd \leq 4\sqrt{f'_c}(bd)$$

$$\rho = \frac{A_s}{bd} = \frac{0.816}{(12'')(9.125'')} = 0.00745 \quad \text{Equation (2.4-5)}$$

$$V_c = \left(2.14\sqrt{(4000)} + 4600(0.00745) \frac{(7.5)(9.125'')\left(\frac{1'}{12''}\right)}{26.60} \right) (12'')(9.125'')$$

$$= 15.62 \text{ kips} \leq 4\sqrt{f'_c}(bd) = 4\sqrt{4000}(12)(9.125)$$

$$= 27701.55 \text{ lbs} = 27.70 \text{ kips} \quad \text{O.K.}$$

$V_u = 7.50 \text{ kips}$
 $\phi V_n = 0.85(15.62) = 13.28 \text{ kips} > V_u \quad \text{O.K.}$

- 5) Check slenderness effect for Member #1:
 $L_u = 12' = 144''$ clear wall height
 $r = (0.3)(12'' \text{ wall thk.}) = 3.6''$
 $K = 0.65$
 $M_{1b} = -21.10 \text{ kips-ft.}$
 $M_{2b} = -26.60 \text{ kips-ft. from Step \#2}$

$$\frac{KL_u}{r} < 34 - \left(12 \frac{M_{1b}}{M_{2b}} \right) \quad \text{Equation (2.4-16)}$$

$$\frac{KL_u}{r} = \frac{0.65(144'')}{3.6''} = 26 \quad \dots\dots(1)$$

$$34 - \left(12 \frac{M_{1b}}{M_{2b}} \right) = 34 - \left(12 \frac{(-21.1)}{(-26.6)} \right) = 24.52 \quad \dots\dots(2)$$

Thus, slenderness effect will be considered since (1) > (2).

- 6) Check magnified moment for Member #1:
Member thickness, $h = 12''$
Factored axial force, $P_u = 10.69 \text{ kips}$

Minimum eccentricity, $e_{\min} = 0.6 + 0.03h = 0.96' = 0.08'$ *Equation (2.4-22)*

Minimum moment, $M_{\min} = e_{\min} P_u = 0.08(10.69) = 0.8552$ kips-ft. *Equation (2.4-23)*

The moment magnifier, δ_b , shall be determined based on moments M_{1b} and M_{2b} since these moments are greater the minimum moment.

Modulus of elasticity of concrete, $E_c = 33 \gamma_c^{1.5} \sqrt{f_c'} = 33(150)^{1.5} \sqrt{4000}$
 $= 3,834,254$ psi

Moment of inertia, $I_g = \frac{bh^3}{12} = \frac{12''(12'')^3}{12} = 1728$ in.⁴

Determine the maximum moment due to dead load at Section A-A by linear interpolation.

$x = 0.1L = 0.1(13.021') = 1.3021'$

$y = \frac{1}{2}$ of Member #4 thickness = $12''/2 = 6'' = 0.5'$

$$\frac{M_{d @ A-A} - M_{d @ 0.1L}}{x - y} = \frac{M_{d @ 0.0L} - M_{d @ 0.1L}}{x}$$

$$\frac{M_{d @ A-A} - (-4.95)}{1.3021 - 0.5} = \frac{-5.29 - (-4.95)}{1.3021} \quad \rightarrow \therefore M_{d @ A-A} = -5.1594 \text{ kips-ft.}$$

Maximum factored moment due to dead loads, $M_u = 1.3(-5.1594) = -6.71$ kips-ft.

$\beta_d = \frac{\text{Max. moment due to dead loads}}{\text{Max. moment due to total loads}} = \frac{-6.71}{-26.6} = 0.2522$

$EI = \frac{E_c I_g}{(1 + \beta_d)} = \frac{2.5}{(1 + 0.2522)} = 2,116,464,115$ lbs-in.² = 14698 kips-ft.² *Equation (2.4-21)*

$C_m = 0.6 + 0.4 \left(\frac{M_{1b}}{M_{2b}} \right) = 0.6 + 0.4 \left(\frac{-21.1}{-26.6} \right) = 0.917 > 0.4$ **O.K.**

Equation (2.4-19)

$P_u = 10.69$ kips

$K = 0.65$

$L_u = 12'$

$\phi = 0.70$

$P_c = \frac{\pi^2 EI}{(KL_u)^2} = \frac{\pi^2 (14698)}{[(0.65)(12')]^2} = 2384.35$ kips *Equation (2.4-20)*

$\delta_b = \frac{C_m}{\left(1 - \frac{P_u}{\phi P_c}\right)} = \frac{0.917}{\left(1 - \frac{10.69}{0.7(2384.35)}\right)} = 0.92 < 1.0$ *Equation (2.4-18)*

Therefore, use $\delta_b = 1.0$

Magnified moment, $M_m = \delta_b M_u = 1.0(-26.60) = -26.60$ kips-ft. *Equation (2.4-17)*

- 7) Generate Interaction Diagram for Member #1:
 Tensile area of J4 reinforcement, $A_s = 0.816 \text{ in.}^2$ (#6 @ 6.5") from Step #3
 Compressive area of B2 reinforcement, $A'_s = 0.3201 \text{ in.}^2$ (#5 @ 11.5")
 $d = 12" \text{ wall thk.} - 2" \text{ cover} - 1/2" \text{ wearing surf.} - 0.75/2 \text{ (half bar dia.)}$
 $= 9.125"$
 $d' = 1.5" \text{ cover} + 0.625/2 \text{ (half bar dia.)}$
 $= 1.8125"$
 $d'' = 12"/2 \text{ (half wall thk.)} - 2" \text{ cover} - 0.75/2 \text{ (half bar dia.)}$
 $= 3.625"$

See figure below for details of steel reinforcement and dimensions.

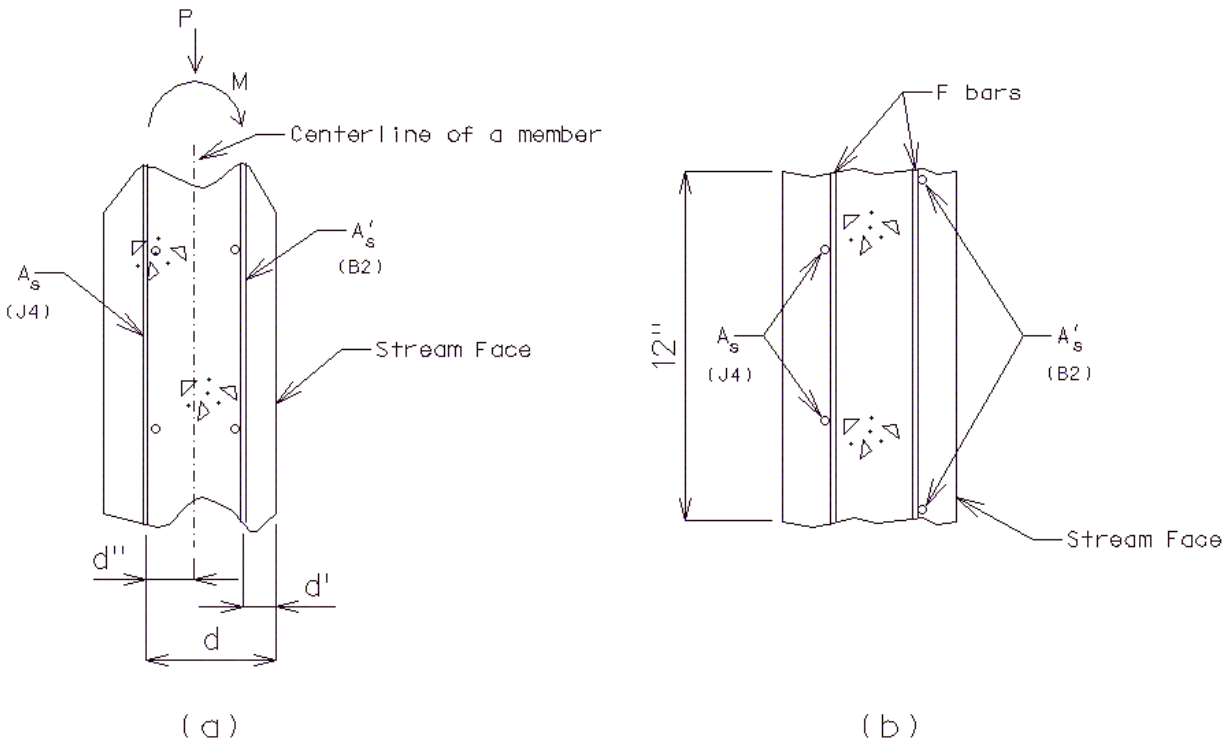

Figure 3.20.2.7-1 Details of steel reinforcement of Member #1 at Section A-A (Figure 3.20.2.6-1) (a) partial elevation view (b) partial plan view

$$A_g = (TX)(12") = (12")(12") = 144 \text{ in.}^2$$

$$A_{st} = A_s + A'_s = 0.816 + 0.3201 = 1.1361 \text{ in.}^2$$

$$\text{Axial capacity, } P^i = 0.85 f'_c (A_g - A_{st}) + A_{st} f_y \quad \text{Equation (2.4-24)}$$

$$= 0.85(4 \text{ ksi})(144 - 1.1361) + (1.1361)(60 \text{ ksi})$$

$$= 553.8938 \text{ kips}$$

Check yielding of compressive reinforcement.

$$\left[\frac{A_s - A'_s}{bd} \right] \geq 0.85 \beta_1 \left(\frac{f'_c d'}{f_y d} \right) \left(\frac{87000}{87000 - f_y} \right) \quad \text{Equation (2.4-28)}$$

$$\left[\frac{A_s - A'_s}{bd} \right] = \left[\frac{0.816 - 0.3201}{(12'')(9.125'')} \right] = 4.5288 \times 10^{-3} \dots\dots(1)$$

$$0.85\beta_1 \left(\frac{f'_c d'}{f_y d} \right) \left(\frac{87000}{87000 - f_y} \right) = 0.85(0.85) \left[\frac{(4)(1.8125'')}{(60)(9.125'')} \right] \left(\frac{87000}{87000 - 60000} \right)$$

$$= 3.0828 \times 10^{-2} \dots\dots(2)$$

Since a value of (1) is less than (2) above, it indicates that compressive reinforcement does not yield before the tension steel does. Therefore, nominal moment is computed based on single steel reinforcement only.

Nominal moment, $M_n = A_s f_y \left(d - \frac{a}{2} \right)$ *Equation (2.4-3)*

$$a = \frac{A_s f_y}{0.85(f'_c) b} = \frac{(0.816)(60)}{0.85(4)(12'')} = 1.2''$$
 Equation (2.4-4)

$$M_o = M_n = A_s f_y \left(d - \frac{a}{2} \right) = 0.816(60) \left(9.125 - \frac{1.2}{2} \right)$$

$$= 417.3840 \text{ kips-in.}$$

Balanced axial load, $P_b = 0.85 f'_c (b)(a_b) + A'_s f'_s - A_s f_y$ *Equation (2.4-25)*

$$a_b = \frac{87000}{(87000 + f_y)} \beta_1 d = \frac{87000}{(87000 + 60000)} (0.85)(9.125'') = 4.5904''$$

Check yielding of compressive reinforcement.

$$f'_s = 87000 \left[1 - \left(\frac{d'}{d} \right) \left(\frac{87000 + f_y}{87000} \right) \right] \leq f_y$$
 Equation (2.4-27)

$$= 87000 \left[1 - \left(\frac{1.8125}{9.125} \right) \left(\frac{87000 + 60000}{87000} \right) \right] = 57.80 \text{ ksi} < f_y = 60$$

Since $f'_s < f_y$, this indicates that the compressive reinforcement will not yield before tension steel. Therefore, $f'_s = 57.80$ ksi.

$$P_b = 0.85(4 \text{ ksi})(12'')(4.5904'') + (0.3201)(57.80 \text{ ksi}) - (0.816)(60 \text{ ksi})$$

$$= 156.8301 \text{ kips}$$

Balanced Moment,

$$M_b = 0.85 f'_c (b)(a_b) \left(d - d'' - \frac{a_b}{2} \right) + A'_s f'_s (d - d' - d'') + A_s f_y d''$$

$$M_b = 0.85(4 \text{ ksi})(12'')(4.5904'')(9.125'' - 3.625'' - 4.5904''/2)$$

$$+ (0.3201)(57.80 \text{ ksi})(9.125'' - 1.8125'' - 3.625'')$$

$$+ (0.816)(60 \text{ ksi})(3.625'')$$

$$= 845.9269 \text{ kips-in.}$$

Strength reduction factor, $\phi = 0.7$ for tied stirrups.

$$\phi P_o = (\phi)(\alpha)P' = (0.7)(0.8)(553.8938) = 310.1805 \text{ kips for pure axial load}$$
$$\phi M_o = 0.7(417.3840) = 292.1688 \text{ kips-in. for pure bending moment}$$

At balanced point,

$$\phi P_b = 0.7(156.8301) = 109.7811 \text{ kips}$$
$$\phi M_b = 0.7(845.9269) = 592.1488 \text{ kips-in.}$$

Determine axial load where strength reduction factor of 0.7 increases linearly to 0.9 from compression to flexure member.

$$P = 0.1 f_c' A_g = 0.1(4 \text{ ksi})(144 \text{ in.}^2) = 57.6 \text{ kips} < \phi P_b$$

Thus, $P = 57.6$ kips (as shown at Point 4 in Figure 3.20.2.7-2)

$$\phi M_o = 0.9(417.3840) = 375.6456 \text{ kips-in. for pure bending moment}$$

without axial load

Plot these points below. Then, the result of interaction diagram is shown as solid line in Figure 3.20.2.7-2.

- Point 1, ($P = 387.73$ kips, $M = 0$ kips-in.)
- Point 2, ($P = 109.78$ kips, $M = 592.15$ kips-in.)
- Point 3, ($P = 0$ kips, $M = 292.17$ kips-in.)
- Point 4, ($P = 57.60$ kips, $M =$ intersection point)
- Point 5, ($P = 0$ kips, $M = 375.65$ kips-in.)
- Point 6, ($P = 310.18$ kips, $M =$ intersection point)

Plot factored axial load and factored moment on Figure 3.20.2.7-2.

$$\text{Axial load, } P_u = 10.69 \text{ kips}$$
$$\text{Moment, } M_u = -26.60 \text{ kips-ft.} = 319.20 \text{ kips-in.}$$

Since this point (i.e., marked as plus sign) is located within the solid line on the graph, it means that the capacity of this section is adequate.

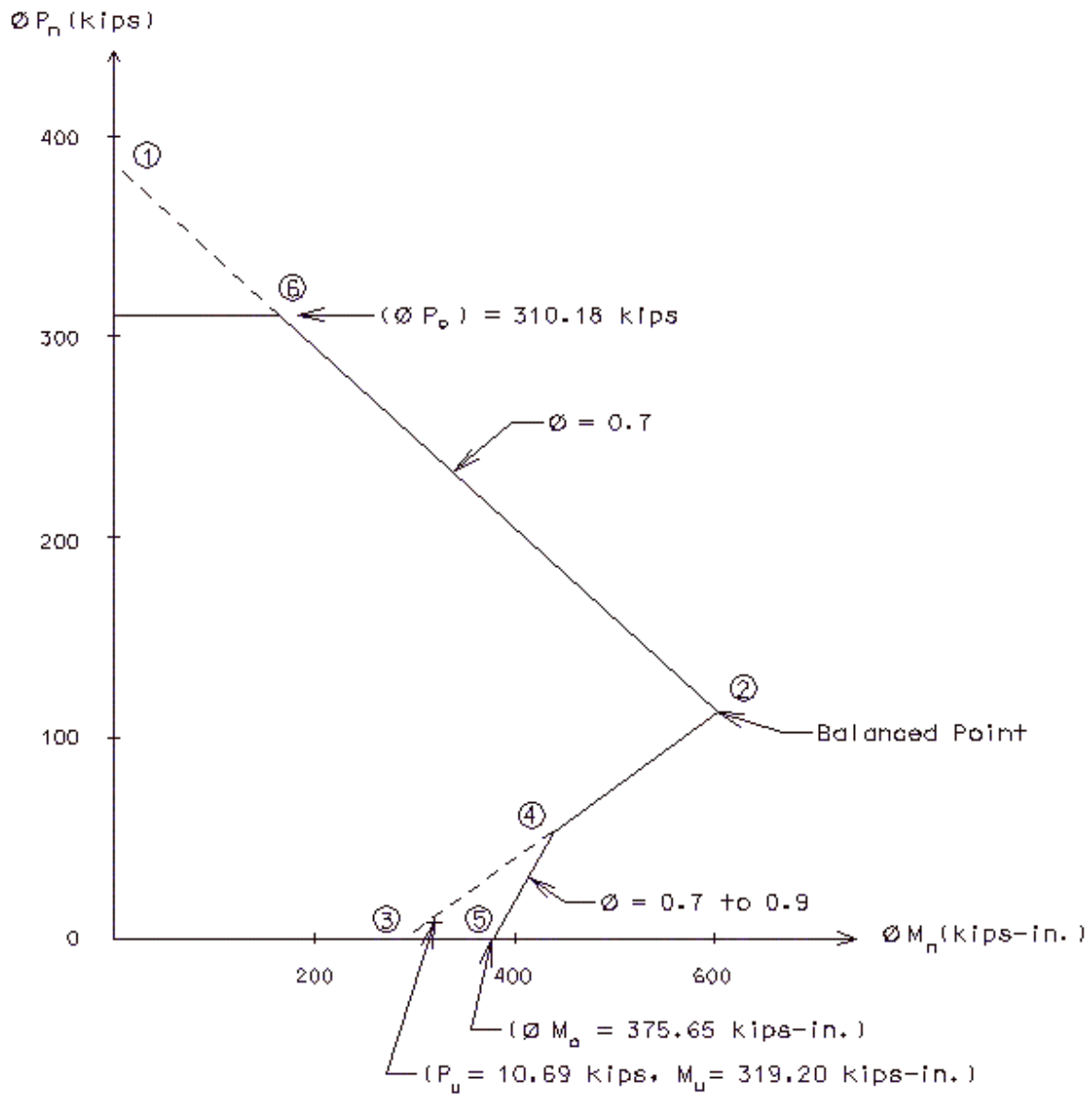

Figure 3.20.2.7-2 Interaction diagram for Member #1

2.8 Design Example 3: Steel Reinforcement Design for J5 bar

Design vertical reinforcement J5 bar in wing wall based on factored moment and shear at the critical Section B-B as shown in Figure 3.20.2.8-1.

Given:

- Compressive strength of concrete, f'_c = 4000 psi
- Minimum yield strength of steel reinf., f_y = 60000 psi
- Effective unit weight of backfill, γ_s = 120 pcf
- Internal friction angle of backfill, ϕ = 27° (conservative)
- Wall thickness, TX = 9"
- Wall height, HT = 10'
- Top slab thickness, TS = 11"
- Backfill slope, β = 18.4349° (1:3) (vertical : horizontal)
- Skew angle = zero (square)
- Straight wing

Solution:

Loads - Live load surcharge is neglected for wing steel reinforcement as specified in Section 3.20.2.2. Self-weight of wing wall and water pressure are also neglected. Use Coulomb active earth pressure as horizontal load against wing wall.

Assumptions - Since wing wall height varies with wing slope, a design wall height can be assumed at a high quarter point of wing length (i.e., $3/4L$) as shown in Figure 3.20.2.8-1. The design critical section is at the interface between the bottom slab and wing wall. The wall can be analyzed and designed as a cantilever beam.

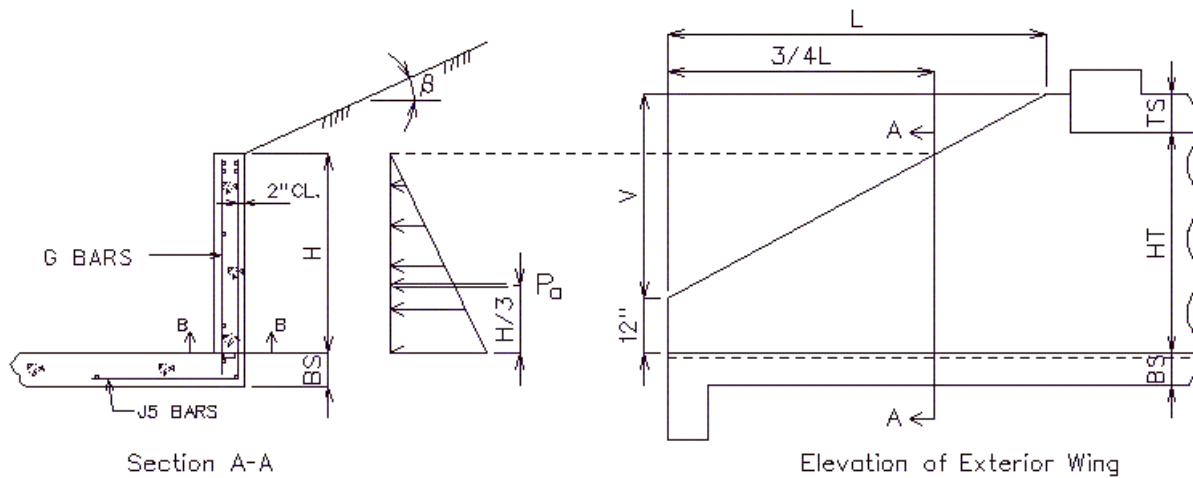

Figure 3.20.2.8-1 Elevation and partial cross section of wing

- 1) Determine design wall height:

$$\begin{aligned} \text{Wing length, } L &= 2(V) \\ V &= HT + TS - 12'' \\ &= 10'(12'') + 11'' - 12'' \\ &= 119'' \end{aligned}$$

$$\begin{aligned} L &= 2(119'') = 238'' \\ 3/4(L) &= 178.5'' \end{aligned}$$

$$\begin{aligned} \text{Design wall height, } H &= 12'' \text{ min. wall height} + 3/4(L)(V/L) \\ &= 12'' + (178.5'')(119/238) = 101.25'' \end{aligned}$$

- 2) Determine active earth pressure:

$$K_a = \frac{\sin^2(\theta + \phi)}{\sin^2(\theta) \sin(\theta - \delta) \left[1 + \sqrt{\frac{\sin(\phi + \delta) \sin(\phi - \beta)}{\sin(\theta - \delta) \sin(\theta + \beta)}} \right]^2} \quad \text{Equation (2.2-6)}$$

$$= 0.463$$

where

$$\delta = (2/3)\phi = (2/3)(27^\circ) = 18^\circ$$

Thus, active earth pressure, P_a

$$P_a = \frac{1}{2} \gamma_s K_a H^2 = \frac{1}{2} (120 \text{ pcf}) (0.4637) (101.25'' \frac{1'}{12''})^2 \quad \text{Equation (2.2-5)}$$

$$= 1980.69 \text{ lbs} = 1.98 \text{ kips}$$

Say active pressure, $P_a = 2 \text{ kips}$

- 3) Determine steel reinforcement J5:

Try #4 for J5 bar,

$$\text{Moment arm, } L = 1/3(H) = 1/3(101.25'') = 33.75'' = 2.8125'$$

$$\text{Moment, } M = P_a (L) = (2)(2.8125') = 5.625 \text{ kips-ft.}$$

$$\text{Factored moment, } M_u = 1.3(M) = 1.3(5.625) = 7.3125 \text{ kips-ft.}$$

$$\begin{aligned} \text{Effective depth, } d &= \text{wall thk.} - 2'' \text{ cover} - 1/2 \text{ bar dia.} - 1/2'' \text{ wearing surf.} \\ &= 9'' - 2'' - 1/2(1/2'') - 1/2'' = 6.25'' \end{aligned}$$

$$R_u = \frac{M_u}{\phi b d^2} = \frac{7.3125(1000)(12'')}{0.9(12'')(6.25'')^2} = 208.00 \text{ psi}$$

$$\rho = \frac{0.85 f_c'}{f_y} \left[1 - \sqrt{1 - \frac{2R_u}{0.85 f_c'}} \right] = 3.5797 \times 10^{-3}$$

$$\rho_b = \frac{0.85 \beta_1 f_c'}{f_y} \left(\frac{87000}{87000 + f_y} \right) = 2.8507 \times 10^{-2}$$

$$\begin{aligned} \rho_{\max} &= 0.75(\rho_b) = 2.1380 \times 10^{-2} \\ h &= TX = 9'' \end{aligned}$$

$$\rho_{\min} = 1.7 \left(\frac{h}{d} \right)^2 \frac{\sqrt{f_c'}}{f_y} = 3.7158 \times 10^{-3}$$

Since $\rho_{\min} > \rho$, then use smaller of $4/3(\rho)$ or ρ_{\min}

$$4/3(\rho) = 4.7730 \times 10^{-3} > \rho_{\min} \quad \therefore \text{Use } \rho = \rho_{\min} = 3.7158 \times 10^{-3}$$

$$\text{Steel area required, } A_s = \rho bd = (3.7158 \times 10^{-3})(12'')(6.25'') = 0.358 \text{ in.}^2/\text{ft.}$$

Use #4 bar spacing at 6-1/2" centers ($A_s = 0.363 \text{ in.}^2$)

- 8) Check shear capacity at critical Section B-B:

Shear force, $V = P_a = 2$ kips

Factored shear force, $V_u = 1.3(V) = 1.3(2) = 2.6$ kips

$$b = 12''$$

$$d = 6.25''$$

$$V_c = 2\sqrt{f'_c}(bd) = 9.49 \text{ kips} \quad \text{Equation (2.4-15)}$$

$$\phi V_n = \phi V_c = 0.85(9.49) = 8.07 \text{ kips} > V_u \quad \text{O.K.}$$

Check minimum shear reinforcement.

$$\frac{1}{2}\phi V_n = 4.03 \text{ kips} > V_u \quad \text{Equation (2.5-3)}$$

\therefore Minimum shear reinforcement is not required.

2.9 Design Example 4: Edge Beam Design

Design steel reinforcement for edge beam shown in Figure 3.20.2.9-1 based on factored moment and shear.

Given:

- Compressive strength of concrete, f'_c = 4000 psi
- Minimum yield strength of steel reinf., f_y = 60000 psi
- Density of earth fill, γ_e = 120 pcf
- Density of concrete, γ_c = 150 pcf
- Exterior wall thickness, TX = 12"
- Interior wall thickness, TI = 12"
- Top slab thickness, TS = 12.5"
- Clear span length, S = 14'
- Skew angle = 30°
- Earth fill depth, H = 2'-5" (from top of top slab to roadway surface)
- Design Live Load = HS20 truck

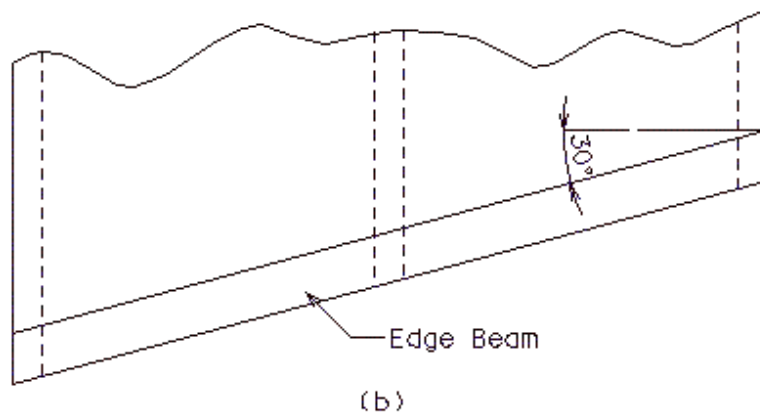
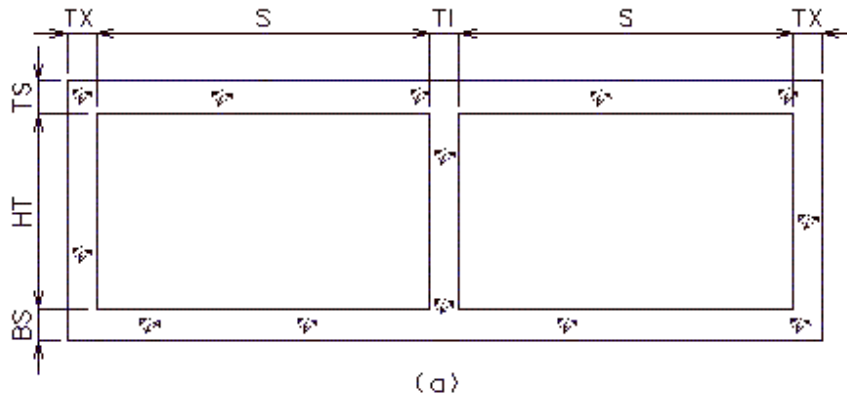

Figure 3.20.2.9-1 (a) Typical cross section of double box culvert (b) partial plan view of culvert showing edge beam

Solution:

Assume edge beam with dimensions of 20" x 18.5" as depicted in Figure 3.20.2.9-2.

- 1) Compute dead loads:

Assumptions - i) half of dead load in hatched areas (Figure 3.20.2.9-2) is carried by the wall and the other half is carried by the beam as a triangular load, and ii) weights of beam and fill over the beam are applied as a uniform load as shown in Figure 3.20.2.9-3.

Earth fill on the top of top slab = 2'-5" = 2.42'

Earth fill on the top of beam = 2.42' – 0.5' = 1.92'

Thus, Impact factor, I = 20% (Section 3.20.2.4)

Hatched area, A = (8.95')(15.5')(1/2) = 69.3625 in.²

$$\begin{aligned} \text{Resultant force, } F &= (A/2)\{(\text{earth fill})(\gamma_e) + (\text{slab thk.})(\gamma_c)\} \\ &= (69.3625/2)\{(2.42')(0.120) + (1.042')(0.150)\} \\ &= 15.48 \text{ kips} \end{aligned}$$

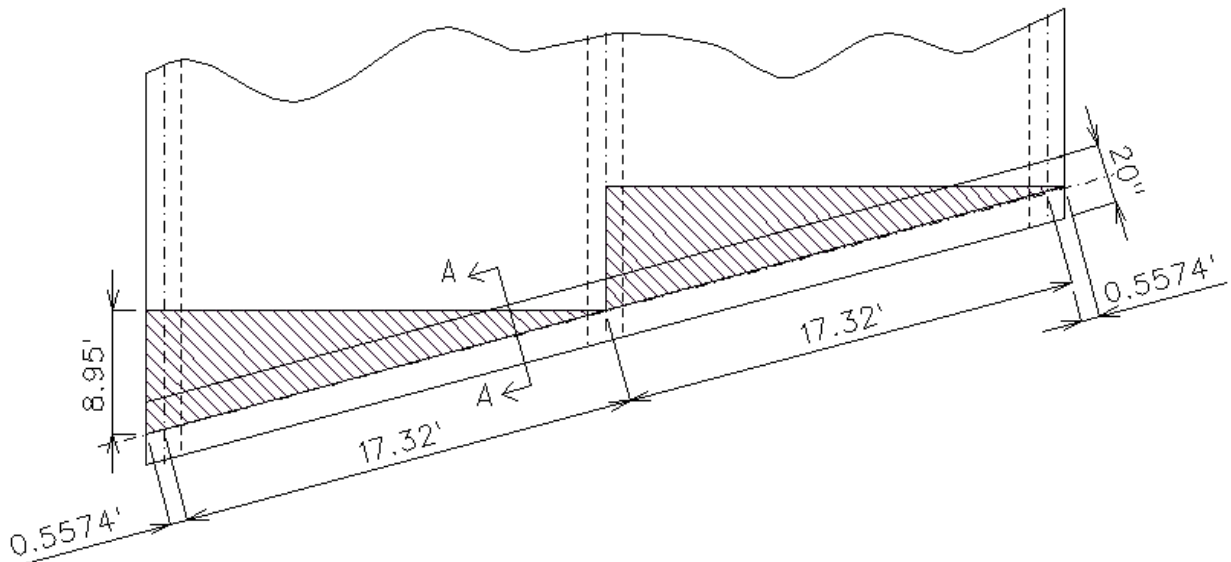
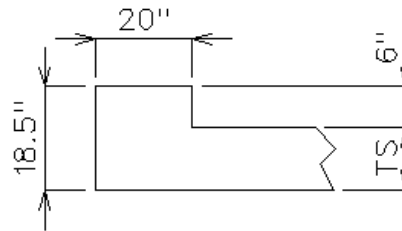

Figure 3.20.2.9-2 Partial plan view of double box culvert showing hatched area where dead loads are considered

$$\text{Equivalent triangular load, } W_1 = \frac{2F}{L} = \frac{2(15.48)}{17.32'} = 1.7871 \text{ kip/ft.}$$

Determine uniform loads:

$$\begin{aligned} \text{Fill weight, } W_2 &= (\gamma_e)(\text{earth fill} - 6")(\text{beam width}/2) \\ &= (0.120)(2.42' - 0.5')(0.8333') \\ &= 0.192 \text{ kip/ft.} \end{aligned}$$

$$\begin{aligned} \text{Half weight of beam, } W_3 &= (\gamma_c)(\text{beam depth})(\text{beam width}/2) \\ &= (0.150)(1.542)(0.8333') \\ &= 0.193 \text{ kip/ft.} \end{aligned}$$

$$\begin{aligned} \text{Additional weight of beam, } W_4 &= (\gamma_c - \gamma_e)(\text{beam depth} - \text{slab thk.})(\text{beam width}/2) \\ &= (0.150 - 0.120)(1.542 - 1.042)(0.8333') \\ &= 0.0125 \text{ kip/ft.} \end{aligned}$$

$$\begin{aligned} \text{Total weight, } W_T &= W_2 + W_3 + W_4 \\ &= 0.3975 \text{ kip/ft.} \end{aligned}$$

See figure below for detail of dead load distributions.

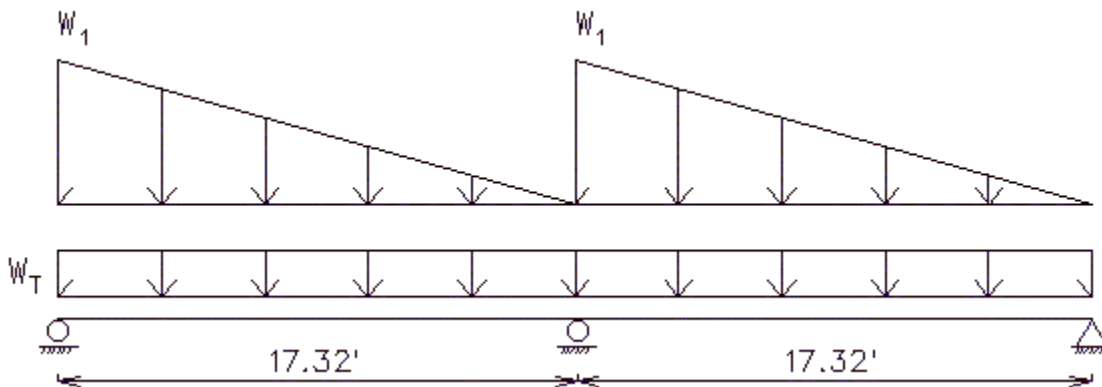

Figure 3.20.2.9-3 Distribution of dead loads on edge beam

- 2) Compute live load:

Positive live load moment for simple span can be approximately determined as below,

$$M = 0.10(P)(L) = 0.1(16 \text{ kips})(17.32') = 27.712 \text{ kips-ft.} \quad \text{Equation (2.2-4)}$$

A computed live load moment can be reduced by 20% for continuous span.

$$M_L = (80\%)(M) = 22.17 \text{ kips-ft.}$$

- 3) Design positive reinforcement:

Dead load moment, $M_d = 29.98$ kips-ft. near mid span #1 (from structural analysis)

$$\text{Live load moment, } M_L = 22.17 \text{ kips-ft.}$$

$$\begin{aligned} \text{Factored moment, } M_u &= 1.3 \{1.0(M_d) + 1.67(M_L + I)\} \\ &= 1.3 \{1.0(29.98) + 1.67(22.17)(1.2 \text{ impact})\} \\ &= 96.73 \text{ kips-ft.} \end{aligned}$$

Try #7 bar with #5 stirrup.

$$\begin{aligned} \text{Effective depth, } d &= (\text{beam thk.}) - (1.5" \text{ cover}) - (\text{stirrup bar dia.}) - (\frac{1}{2} \text{ bar dia.}) \\ &= 18.5" - 1.5" - 0.625" - (0.875"/2) = 15.9375" \end{aligned}$$

$$R_u = \frac{M_u}{\phi b d^2} = \frac{96.73(1000)(12")}{0.9(20")(15.9375")^2} = 253.88 \text{ psi}$$

$$\rho = \frac{0.85 f_c'}{f_y} \left[1 - \sqrt{1 - \frac{2R_u}{0.85 f_c'}} \right] = 4.4023 \times 10^{-3}$$

$$\rho_b = \frac{0.85 \beta_1 f_c'}{f_y} \left(\frac{87000}{87000 + f_y} \right) = 2.8507 \times 10^{-2}$$

$$\begin{aligned} \rho_{\max} &= 0.75(\rho_b) = 2.1380 \times 10^{-2} \\ h &= 18.5" \end{aligned}$$

$$\rho_{\min} = 1.7 \left(\frac{h}{d} \right)^2 \frac{\sqrt{f_c'}}{f_y} = 2.4145 \times 10^{-3}$$

∴ Use $\rho = 4.4023 \times 10^{-3}$ since $\rho_{\min} < \rho < \rho_{\max}$

Steel area required, $A_s = \rho b d = (4.4023 \times 10^{-3})(20")(15.9375") = 1.403 \text{ in.}^2/\text{ft}$.
3-#7 bars ($A_s = 1.80 \text{ in.}^2$) is adequate. However, steel reinforcement of edge beam shall be at least equal to steel area in standard headwall as shown in Figure 3.20.4.2-2. Therefore, provide 4-#8 at bottom of the beam for positive moment.

Use 4-#8 bars for positive moment

4) Design negative reinforcement:

Dead load moment, $M_d = -48.14 \text{ kips-ft.}$ (from structural analysis)

Live load moment, $M_L = -22.17 \text{ kips-ft.}$

$$\begin{aligned} \text{Factored moment, } M_u &= 1.3 \{1.0(M_d) + 1.67(M_L + I)\} \\ &= 1.3 \{1.0(48.14) + 1.67(22.17)(1.2 \text{ impact})\} \\ &= -120.34 \text{ kips-ft.} \end{aligned}$$

Try #7 bar with #5 stirrup.

$$\begin{aligned} \text{Effective depth, } d &= (\text{beam thk.}) - (1.5" \text{ cover}) - (\text{stirrup bar dia.}) - (\frac{1}{2} \text{ bar dia.}) \\ &\quad - \frac{1}{2}" \text{ wearing surface} \\ &= 18.5" - 1.5" - 0.625" - (0.875"/2) - 0.5" = 15.4375" \end{aligned}$$

$$R_u = \frac{M_u}{\phi b d^2} = \frac{120.34(1000)(12")}{0.9(20")(15.4375")^2} = 336.64 \text{ psi}$$

$$\rho = \frac{0.85 f_c'}{f_y} \left[1 - \sqrt{1 - \frac{2R_u}{0.85 f_c'}} \right] = 5.9199 \times 10^{-3}$$

$$\rho_b = \frac{0.85 \beta_1 f_c'}{f_y} \left(\frac{87000}{87000 + f_y} \right) = 2.8507 \times 10^{-2}$$

$$\rho_{\max} = 0.75(\rho_b) = 2.1380 \times 10^{-2}$$

$$h = 18.5''$$

$$\rho_{\min} = 1.7 \left(\frac{h}{d} \right)^2 \frac{\sqrt{f'_c}}{f_y} = 2.5735 \times 10^{-3}$$

∴ Use $\rho = 5.9199 \times 10^{-3}$ since $\rho_{\min} < \rho < \rho_{\max}$

Steel area required, $A_s = \rho b d = (5.9199 \times 10^{-3})(20'')(15.4375'') = 1.83 \text{ in.}^2/\text{ft}$.
 3-#7 bars ($A_s = 1.80 \text{ in.}^2$) is adequate. However, steel reinforcement of edge beam shall be at least equal to steel area in standard headwall as shown in Figure 3.20.4.2-2. Therefore, provide 2-#8 and 2-#9 at top of the beam for negative moment.

Use 2-#8 and 2-#9 bars for negative moment

Determine cut-off length for #9 bar.

Use larger of 48 bar diameter or 1/4 of clear span length of the beam,

$$48(1'' \text{ diameter}) = 48'' = 4'$$

$$\frac{1}{4}\{(17.32') - (2)(0.5574')\} = 4.0513' \quad \dots \text{controls}$$

$$\begin{aligned} \text{Total length of \#9 bar} &= (2 \text{ sides})(4.0513') \\ &= 8.10' \end{aligned}$$

Note: provide length of 2-#8 bars the full length of the beam.

5) Check shear strength:

The critical shear at a distance “d” from the face of interior support is near the location of 0.1L.

Dead load shear, $V_d = -12.91 \text{ kips @ } 0.1L \text{ of span \#2 (from structural analysis)}$

Live load shear, $V_L = -16.0 \text{ kips}$

$$\begin{aligned} \text{Factored shear, } V_u &= 1.3 \{1.0(V_d) + 1.67(V_L + I)\} \\ &= 1.3 \{1.0(12.91) + 1.67(16.0)(1.2 \text{ impact})\} \\ &= 58.47 \text{ kips} \end{aligned}$$

$$\begin{aligned} \text{Nominal shear, } V_c &= 2\sqrt{f'_c} (bd) = 2\sqrt{4000}(20'')(15.4375'') \\ &= 39054.13 \text{ lbs} = 39.05 \text{ kips} \end{aligned}$$

$$\text{Shear capacity, } \phi(V_n) = 0.85(39.05) = 33.19 \text{ kips} < V_u = 58.47 \text{ kips} \quad \text{N.G.}$$

Therefore, shear reinforcement is required.

Determine shear reinforcement.

$$\begin{aligned} \text{Shear resisted by steel reinf., } V_s &= \frac{V_u}{\phi} - V_c = \frac{58.47}{0.85} - 39.05 \quad \text{Equation (2.4-13)} \\ &= 29.74 \text{ kips} \end{aligned}$$

$$\begin{aligned} \text{Shear steel area, } A_v &= \frac{V_s(s)}{f_y d} = \frac{(29.74 \text{ kips})(12'')}{(60 \text{ ksi})(15.4375'')} \quad \text{Equation (2.4-12)} \\ &= 0.39 \text{ in.}^2 \end{aligned}$$

Use double leg #5 bar spacing at 12” centers ($A_s = 0.61 \text{ in.}^2$)

3.1 Barrel Section

Barrel length is defined as the distance measured along the centerline of the box culvert between inside faces of headwalls. Figure 3.20.3.1-1 shows details of barrel length, fill slope, clear zone, etc.

A section between two transverse joints is called “cut section” as shown in Figure 3.20.3.1-1. The maximum cut section length is 50 feet. A length of 60 feet may be used in special cases such as if the joint falls under roadway (or traveled way).

A minimum clear span length and wall height of all box culverts shall be at least 4 feet with increments of 1 foot.

(1) Top Slab

Minimum slab thickness shall be computed as specified in Section 3.20.2.4 but in no case the slab thickness shall be less than 8”. The slab shall have a uniform thickness and increments of 1”.

If the slab is to be used as roadway surface without earth fill or other cover (i.e., asphalt, etc.), see the Structural Project Manager for possible use of epoxy coated reinforcing bars, higher concrete strength, etc.

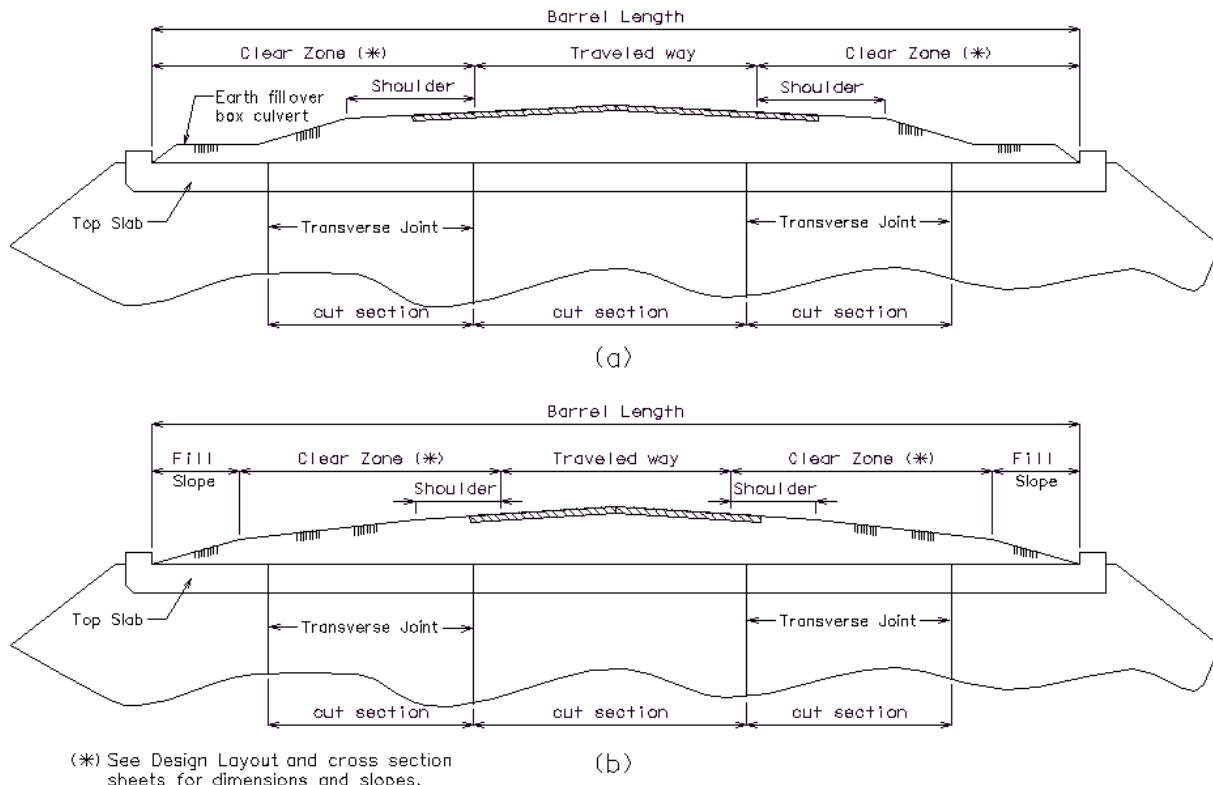

**Figure 3.20.3.1-1 Elevation view along centerline of box culvert
(a) shallow earth fill (b) deep earth fill**

(2) Bottom Slab

Minimum slab thickness shall be computed as specified in Section 3.20.2.4 but in no case the slab thickness shall be less than 8". The slab shall have a uniform thickness and increments of 1".

(3) Walls

The wall shall have a uniform thickness and increments of 1". Minimum wall thickness shall not be less than 8".

When a box culvert is built on a rock foundation without bottom slab, the bottom of walls should be extended into the rock at least 6" full length as shown in Figure 3.20.3.1-2.

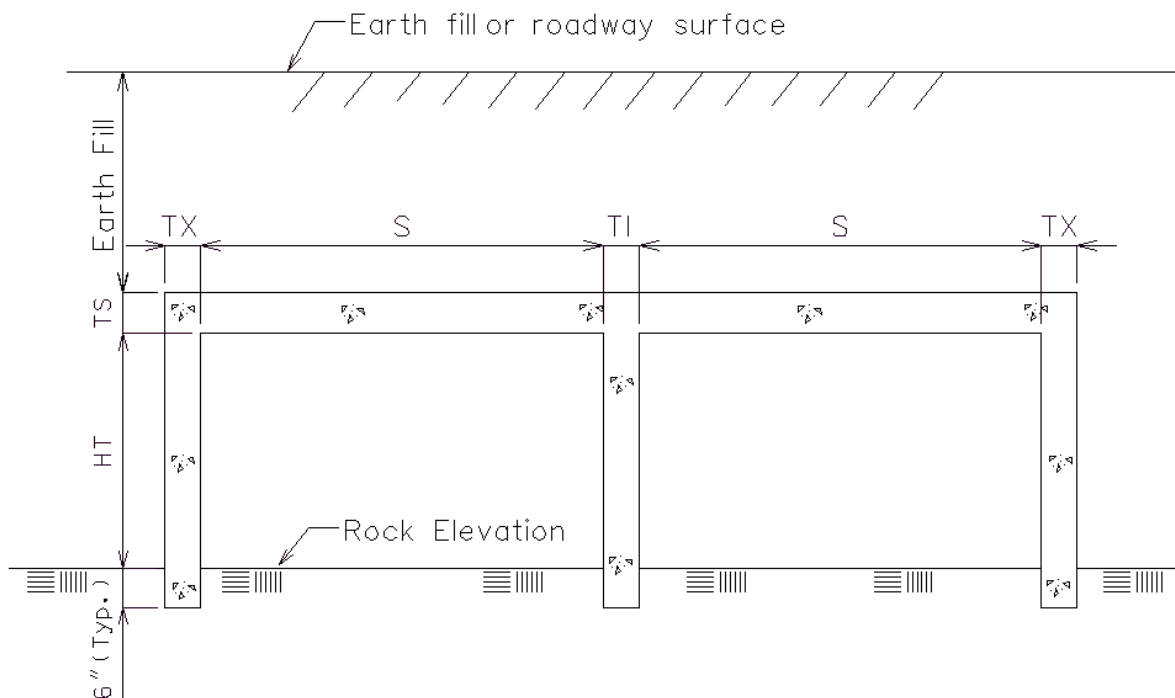

Figure 3.20.3.1-2 Typical cross section of culvert on a rock foundation

Additional Sections

There are two types of additional sections, "Dog-Leg" and "Broken Back". Dog-Leg and Broken Back are defined as sections of box culvert having single and double turns along their lengths, respectively (Figure 3.20.3.1-3). A transverse joint should not be located within that portion which is 5'-0" upstream or 10'-0" downstream from point of deflection as shown in Figure 3.20.3.1-3. See Section 3.20.4.1 for details of the transverse joint.

End Sections

End section of barrel is a section which is located between the inside face of headwall and the first transverse joint (Figure 3.20.1.2-1).

When alternate precast box sections are used, the minimum end section length measured along the shortest wall from the first transverse joint to outside face of headwall shall be larger of 3'-2" or development length l_d of J1 bar as shown in Figure 3.20.4.2-3.

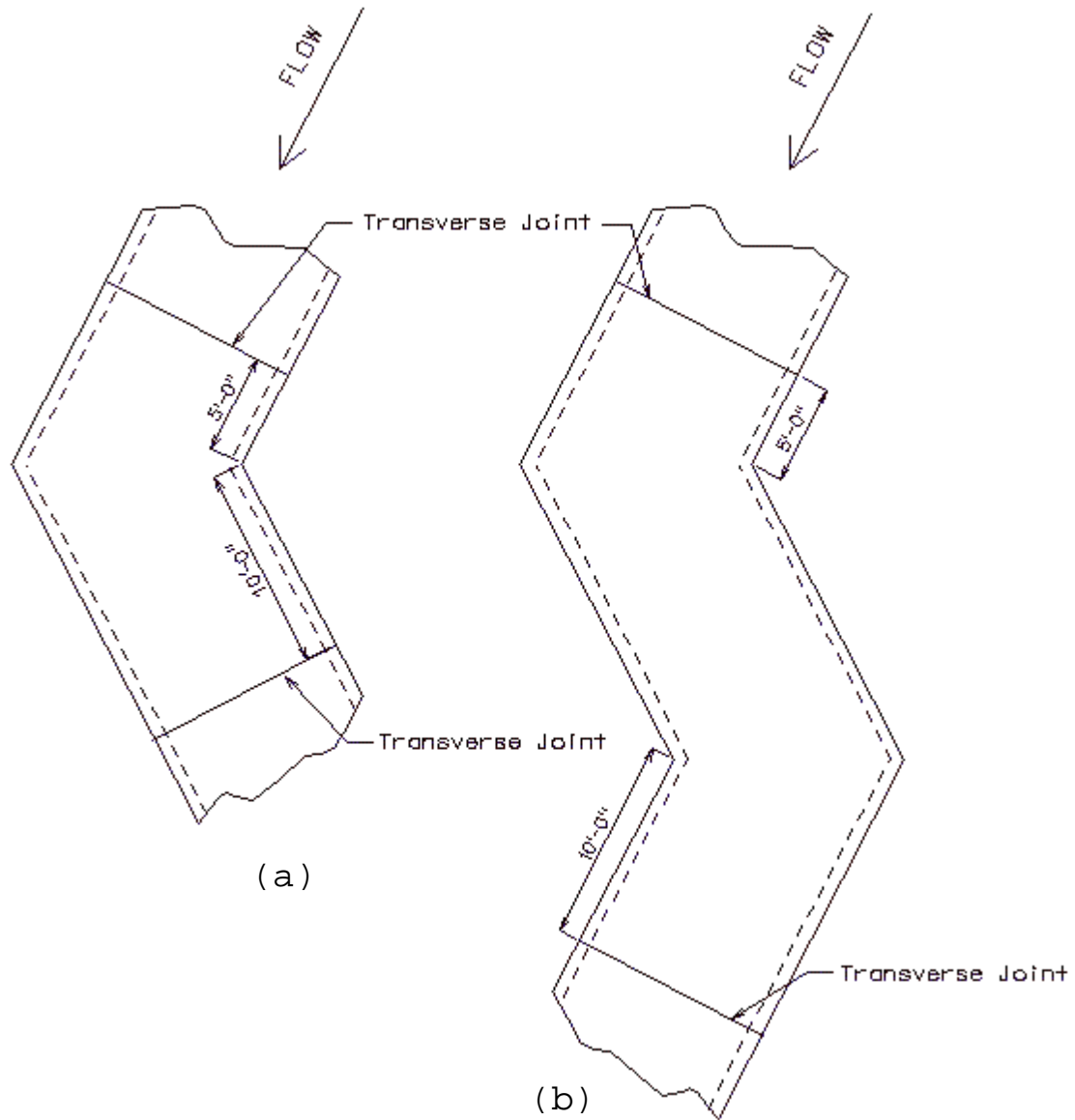

Figure 3.20.3.1-3 Plan view of additional sections (a) Dog-Leg (b) Broken Back

3.2 Wings and Curtain Walls

Wings

Exterior wing walls can be either straight or flared as shown in Figure 3.20.3.2-1. Figure 3.20.3.2-1(a) shows a typical flared wing at a fixed angle of 20 degrees. Figures 3.20.3.2-1(b) and (c) show straight wing without and with skewed angles, respectively. Interior wing walls shall always be parallel along the centerline of the adjoining walls. When a culvert is built on a rock foundation without bottom slab, the bottom of wing walls should be extended into the rock at least 6" as shown in Figure 3.20.3.1-2.

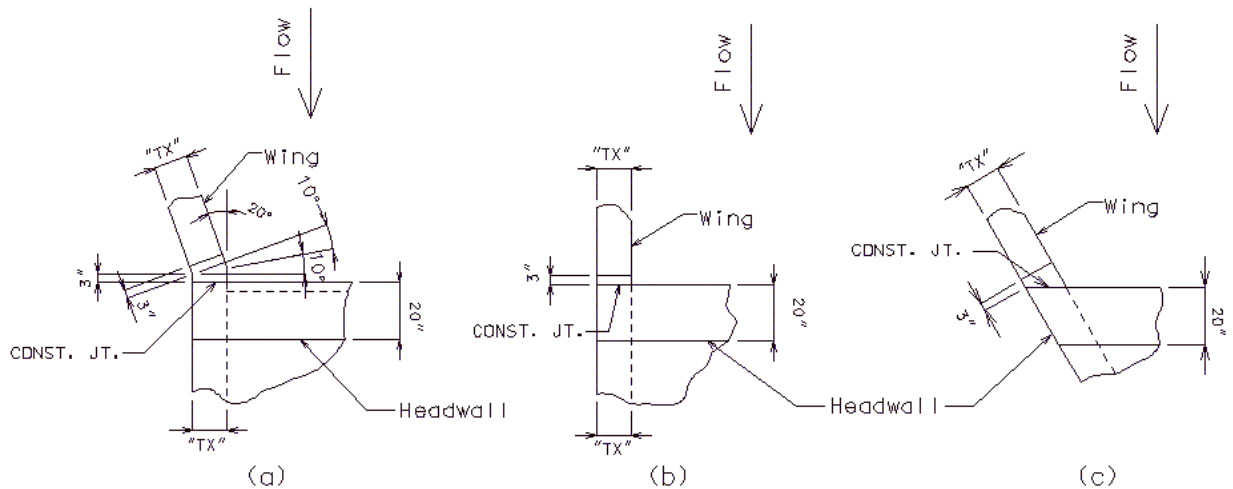

Figure 3.20.3.2-1 Partial details of wing wall (a) flared wing wall (b) straight wing wall with zero skewed angle (c) straight wing wall with skewed angle

(1) Wing thickness

The thickness shall be uniform and same as the adjoining walls.

(2) Wing slope

Slope of 1:2 (vertical “V” to horizontal “G”) shall be maintained for both flared and straight wings as shown in Figure 3.20.3.2-2 where “G” is the wing horizontal distance perpendicular to the traffic direction as shown in Figure 3.20.1.2-2.

(3) Wing length

It is determined based on wall height, skewed and flared angles, and wing slope. Wing length, L shown in Figure 3.20.1.2-2 or 3.20.3.2-2, can be determined using Equations (3.2-1) and (3.2-2) for straight and flared wings, respectively.

$$L = \frac{2V}{\cos(\theta)} \quad \text{for straight wings} \quad \text{Equation (3.2-1)}$$

$$L = \frac{2V}{\cos(\theta + 20^\circ)} \quad \text{for flared wings} \quad \text{Equation (3.2-2)}$$

Where

L = wing length

V = (top slab thk.) + (clear wall ht.) – 12" (Figure 3.20.3.2-2)

θ = skew angle

Wing length shall be that necessary to carry wing on a given slope from a given height down to a point 12" above top surface of the bottom slab for culverts with floor and to a point 12" above theoretical flowline for culverts without floor. See Structural Project Manager when ends of wings exceeds 3'-0" for culverts without floor.

For culverts with bottom slab, all interior wing lengths shall be extended full length to match outside wing walls. Whereas interior wing walls on a rock foundation shall be extended full length on the upstream end only. On the downstream end, interior wing walls on rock beyond the outside face of the headwall shall be omitted. On skewed culverts, interior wing walls on rock at downstream end shall be made flush with the outside face of the headwall.

(4) Wing height

The top of wings shall be flushed with the top of top slab and it shall be made horizontal for a minimum distance of 3" from outside face of headwall before beginning slope as shown in Figures 3.20.3.2-1 and 3.20.3.2-2.

(5) Flared angle

Flared wing shall have an angle of 20 degrees with respect to exterior wall as shown in Figure 3.20.3.2-1(a) or Figure 3.20.1.3-2(d).

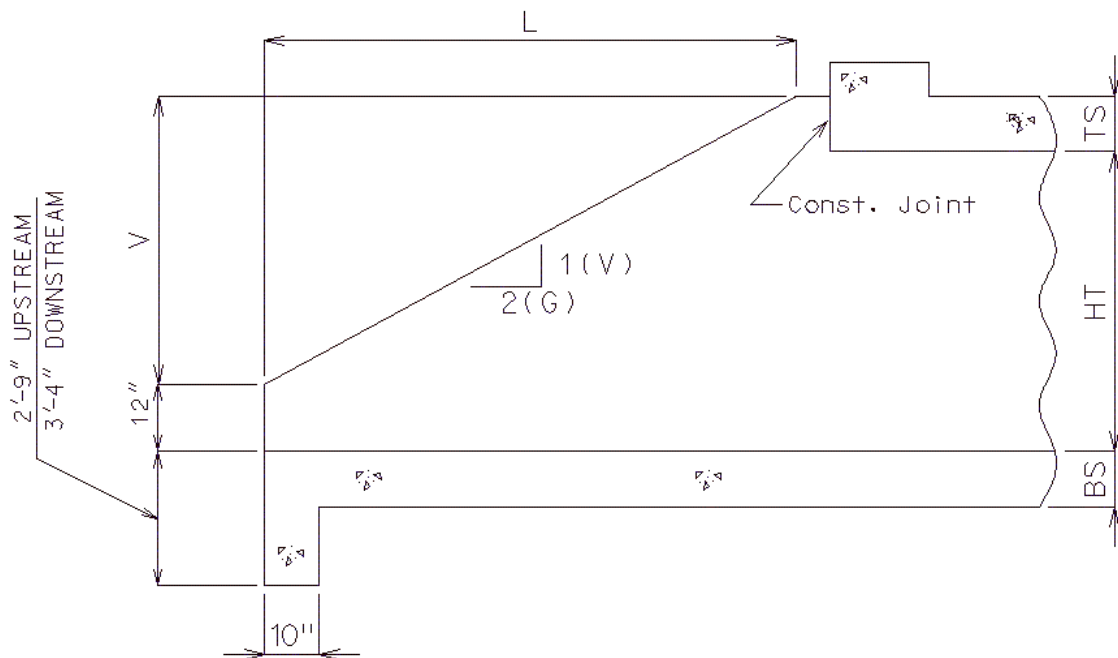

Figure 3.20.3.2-2 Typical dimensions of wing wall

Curtain Walls

Minimum dimensions of curtain walls shall be provided at both ends of box culvert. The depth is measured downward from the top of bottom slab to bottom of the curtain wall. See Figure 3.20.3.2-2 for details.

Minimum thickness = 10"

Minimum depth = 2'-9" at upstream end

= 3'-4" at downstream end

4.1 Joints

Construction Joints

Construction joint shall be located at where headwalls and wings are met as shown in Figures 3.20.3.2-1 and 3.20.3.2-2. Keyed construction joints are located at top and bottom of walls. The width of keyed construction joint shall be at least 1/3 of wall thickness with sides battered 1/4" in the depth. The depth of the key shall be 1" and 2" at the bottom and top of wall, respectively. See Figure 3.20.4.1-1(b) and (c) for details.

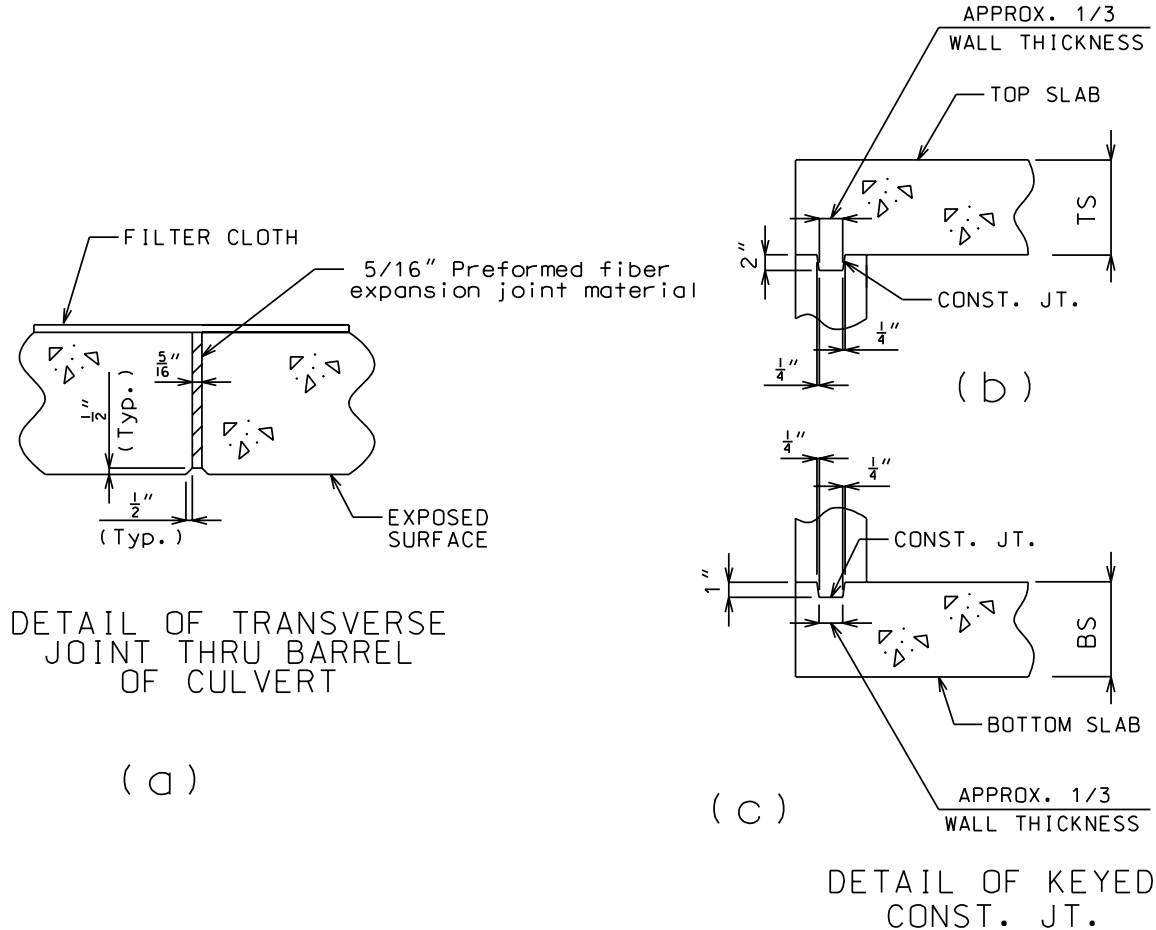

Figure 3.20.4.1-1 Typical detail of joints (a) transverse joint (b) keyed construction joint at top slab (c) keyed construction joint at the bottom slab

Transverse Joint

Transverse joint shall be provided in all box culverts having barrel length over 80'-0" between inside faces of headwalls measured along the centerline of box culvert. For culverts with clear zones, wide roadways, etc., where the barrel length (Figure 3.20.3.1-1) between inside faces of headwalls measured along centerline of culvert does not exceed 90'-0", the joint may be omitted. For box culverts with long barrel length, additional transverse joints may be required. See Section 3.20.3.1 for the maximum length of a cut section between two transverse joints.

If possible, transverse joints shall not be placed directly below roadway (or traveled way). Locate the joint under shoulders or median.

All transverse joints shall be made vertical when the culvert is cambered, indicate vertical on plans, and at right angles to the centerline of barrel. All longitudinal steel reinforcement shall be stopped at least 1-1/2" from joints. These joints shall be filled with 5/16" joint filler. See Figure 3.20.4.1-1(a) for details.

AASHTO 8.24.2.2 and 8.29.3.4

B1 bar - Steel reinforcement shall be designed for maximum combined axial load and moment at interior walls. This bar is spaced vertically near stream faces of the wall. Minimum steel reinforcement of #5 bar spacing at 11.5" centers shall be provided. This bar should be extended into the top and bottom slabs. A hook bar may be required if the embedment length is insufficient due to slab thickness limitations. The embedment length of steel reinforcement shall be at least $8d_b$ or 6". Excess reinforcement criterion may be used to satisfy the minimum embedment length of $8d_b$ or 6".

B2 bar - Steel reinforcement shall be designed for maximum combined positive moment and axial load at exterior walls. This bar is spaced vertically near the stream face of the wall. Minimum steel reinforcement of #5 bar spacing at 11.5" centers shall be provided. This bar should be extended into the top and bottom slabs. A hook bar may be required if the embedment length is insufficient due to slab thickness limitations. The embedment length of steel reinforcement shall be at least $8d_b$ or 6". Excess reinforcement criterion may be used to satisfy the minimum embedment length of $8d_b$ or 6".

J3 bar - Steel reinforcement shall be designed for a maximum negative moment at top slab or exterior wall. This bar is placed vertically along the wall and transversely perpendicular to the centerline of culvert.

J4 bar - Steel reinforcement shall be designed for maximum negative moment at either bottom slab or exterior wall. This bar is placed vertically along the wall and transversely perpendicular to the centerline of culvert.

H1 bar - Steel reinforcement shall be designed for a maximum negative moment at top slab over the interior walls. This bar is placed transversely perpendicular to the centerline of culvert at the top of top slab. Its spacing is alternated with spacing of H2 bar. The length of H1 bar is longer than the length of H2 bar.

H2 bar - Steel reinforcement shall be designed for a maximum negative moment at top slab over the interior walls. This bar is placed transversely perpendicular to the centerline of culvert at the top of top slab. Its spacing is alternated with spacing of H1 bar.

F bar - Longitudinal steel reinforcement provides for temperature and shrinkage control. Use minimum #4 bar spacing at 14" centers. This bar is placed longitudinally parallel to the centerline of culvert. Additional longitudinal reinforcement may be required to provide for lateral distribution of concentrated live loads. See Section 3.20.2.5 for distribution of reinforcement.

(2) Headwalls and edge beams

Figure 3.20.4.2-2 shows a typical cross section through headwalls and edge beams and bar marks of steel reinforcement which are described below:

D1 bar – Place 2-#8 bars at the top of headwalls or edge beams. In addition, provide 4-#8 bars at bottom of headwalls or edge beam when headwall or edge beam is skewed. These bars shall be placed along the headwall or edge beam.

D2 bar – Place these bars between D1 bars at the top of headwalls or edge beam and centered over interior walls. The total length of the bar is equal to two times larger value of 48 bar diameters or $\frac{1}{4}$ clear span length of headwall or edge beam. Neglect this bar for single span and if clear span length along headwall is less than or equal to 10' for multiple spans. Otherwise, use a number of bars and sizes as indicated below:

$$2\text{-}\#8 \text{ bars when } 10' < \left[\frac{\text{clear span length}}{\cos(\text{skew angle})} \right] \leq 13'$$

$$* 2\text{-}\#9 \text{ bars when } 13' < \left[\frac{\text{clear span length}}{\cos(\text{skew angle})} \right]$$

* The required area of steel reinforcement should be checked if clear span length along headwall or edge beam exceeds 20'.

R1 bar – Provide minimum #5 bar spacing at 12" centers. This bar is placed perpendicularly to upstream headwall or edge beam.

R2 bar - Provide minimum #5 bar spacing at 12" centers. This bar is placed perpendicularly to upstream headwall or edge beam.

R3 bar - Provide minimum #5 bar spacing at 12" centers. This bar is placed perpendicularly to downstream headwall or edge beam.

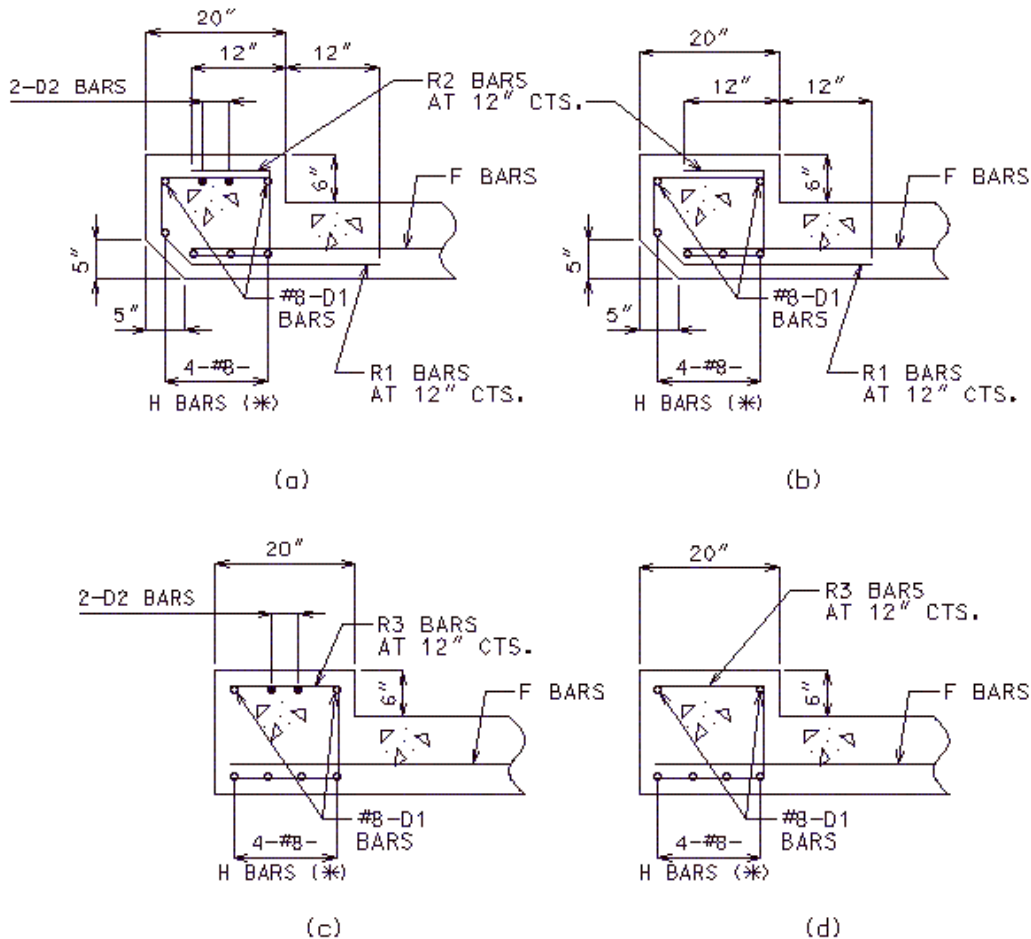

* When headwall or edge beam is skewed.

Figure 3.20.4.2-2 Typical cross section of headwalls or edge beams and details of steel reinforcement (a) upstream headwall over interior wall, (b) upstream headwall or edge beam near mid span, (c) downstream headwall over interior wall, and (d) downstream headwall or edge beam near mid span

(3) Wings

F bar - Longitudinal steel reinforcement provides for temperature and shrinkage control. Use minimum #4 bar spacing at 14" centers. This bar should be placed longitudinally along wing walls as shown in Figure 3.20.4.2-3. For wings on rock, longitudinal F bars should be designed using maximum moment and shear as specified in Section 3.20.2.3.

G bar – Provide the same bar size and spacing as B1 or B2 bar for interior (Figure 3.20.4.2-3(a)) or exterior wall (Figure 3.20.4.2-3(b)), respectively.

J1 bar – Provide 2-#7 bars at each face of wing walls.

J5 bar – Steel reinforcement shall be designed for moment and shear based on Coulomb or Rankine active earth pressure. In any case, the provided steel area of J5 bar shall not be less than that provided by the adjoined wall.

(4) Curtain walls

E bar – Provides 4-#5 bars and they should extend into wing walls as far as practical as shown in Figure 3.20.4.2-3. For wing walls on rock, these bars shall be extended 12" into the rock and grouted.

(5) Collar Beams

Figure 3.20.4.2-4 shows steel reinforcement details of collar beams. The figure also shows that one layer of roofing felt should be provided between culvert and collar beams. This would allow free lateral movement of adjoined sections.

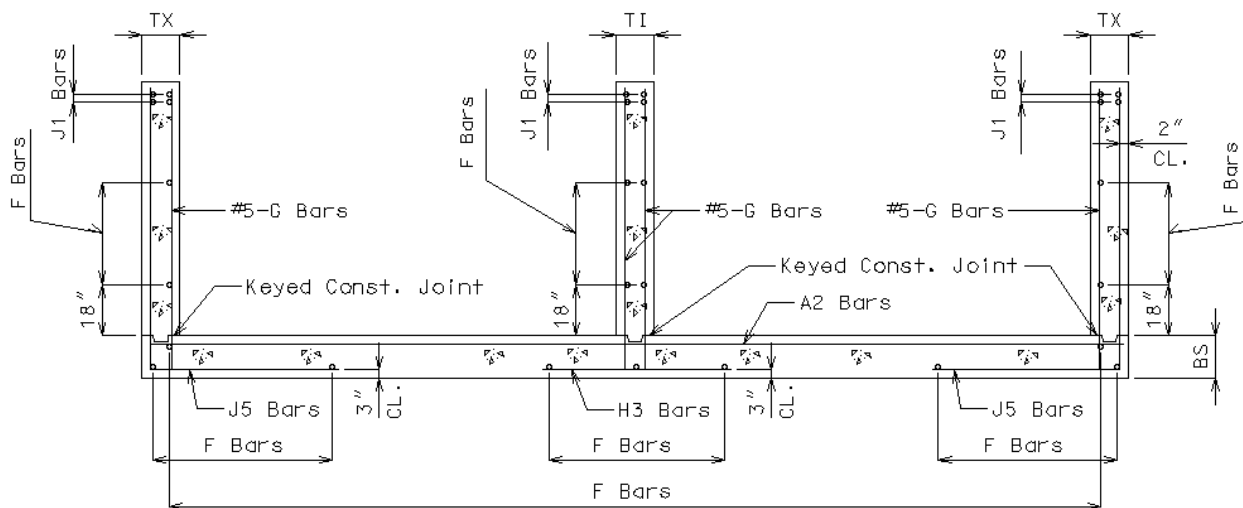

SECTION A-A

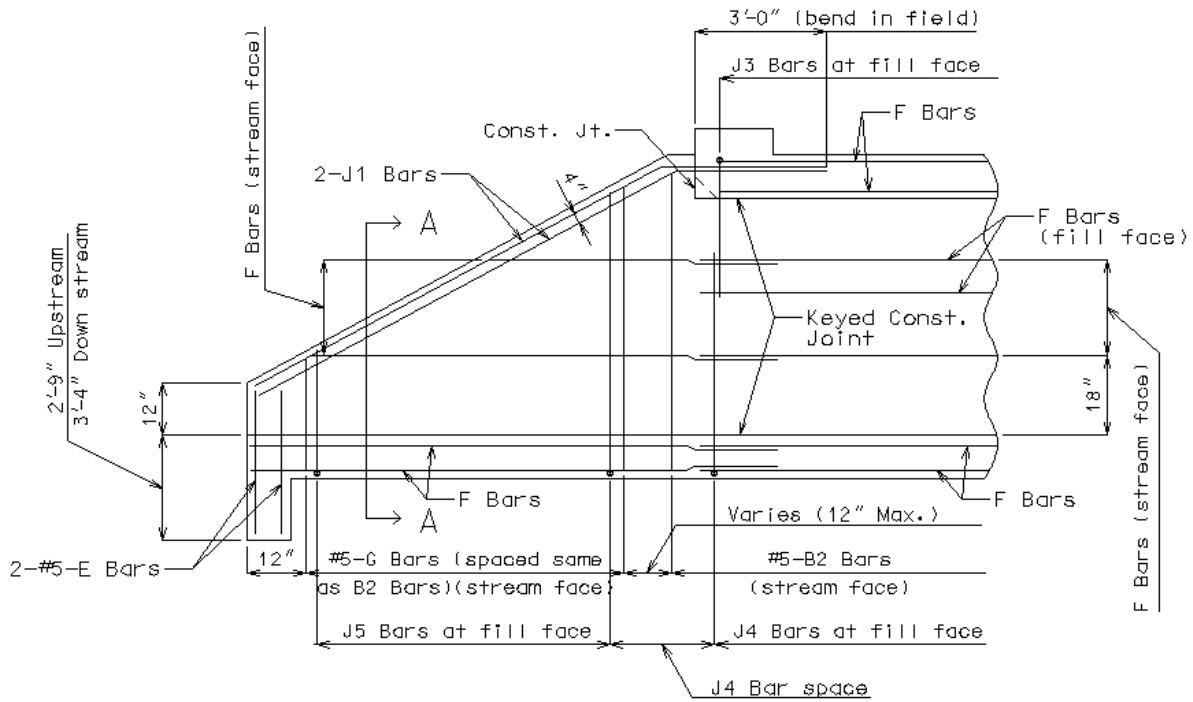

(a) ELEVATION OF EXTERIOR WING

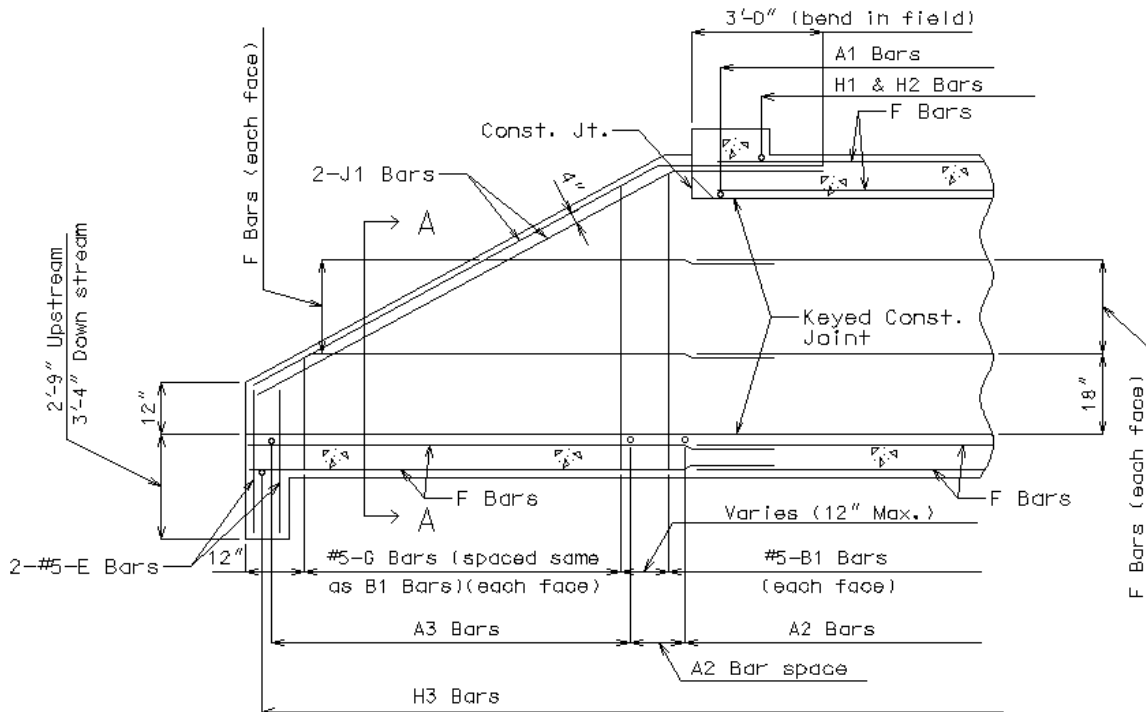

(b) ELEVATION OF INTERIOR WING

For Section A-A, see page 4.2-4 of this section.

Figure 3.20.4.2-3 Elevation views of wings showing bar marks (a) elevation of exterior wing, (b) elevation of interior wing

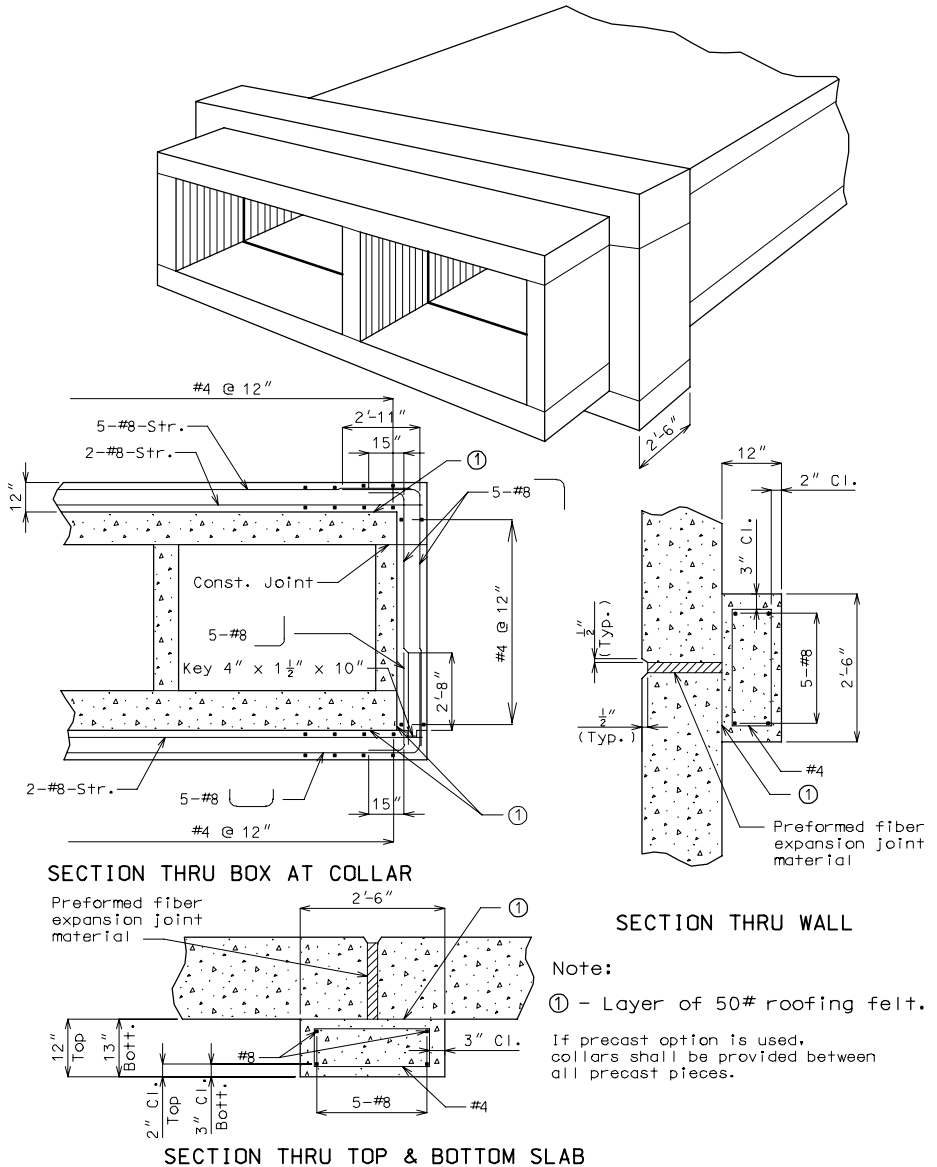

Figure 3.20.4.2-4. Details of Collar Beam

4.3 Survey Data for Plans**(1) General**

Show centerline station, beginning station and design fill depth for each section of culvert. For structures with dual and/or outer roadway, this data shall be shown for each lane.

(2) Location sketch

Where culverts are located on/or within 150 feet of horizontal curves, show complete curve data in "Location Sketch".

Show the required channel changes in "Location Sketch" in general by showing the centerline only and make reference to road plans for details.

Show the size and location of existing channels and other details in "Location Sketch" as accurately as scale of sketch will permit.

Give the amount and classification of the drainage area. Where existing structures are to be removed under lump sum item for removal, show said structures in "Location Sketch" and note that they are to be removed.

For skewed structures on tangents, show the amount of skew by giving the angle between the line normal to the centerline of roadway and a sidewall (not an intermediate wall extended by a dot and dash line).

For skewed structures on horizontal curves, show the amount of skew by giving the angle between the line normal to tangent line and the centerline of structure.

(3) Bench mark

Give the bench mark data near, but not in "General Notes" and keep distinctly separate from main title. Use the following form:

B.M. ELEVATION....., Description, Location

Example: "B.M. ELEVATION 692.30, SPIKE IN 20" OAK 80' RT. OF STATION 718+04.44"

(4) Title

The beginning station as specified on culvert plans shall be the station at fill face of the exterior wall and the centerline of roadway. See Figure 3.20.4.3-1 for sample calculation of beginning station.

(5) Rock Elevations

Rock elevations for box culverts with walls on rock or with bottom slab or curtain walls that encounter rock should be detailed on the plans. Figure 3.20.4.3-2 shows details of Alternative #1 which shall include the sketch of rock locations and a table showing rock elevations. Alternative #2 (Figure 3.20.4.3-3) is similar to Alternative #1 except that rock elevations are shown on the sketch of rock locations.

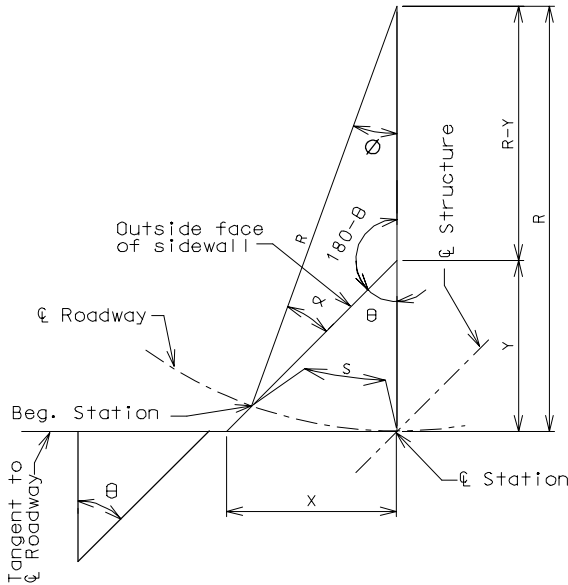

(1) $x \cot \theta = Y$
 (2) $\frac{\sin (180 - \theta)}{R} = \frac{\sin \alpha}{(R-Y)}$
 $\frac{\sin \theta}{R} = \frac{\sin \alpha}{(R-Y)}$
 Find θ
 (3) $S = R\theta$

L.A. Skews Curve Lt.
 R.A. skews Curve Rt.

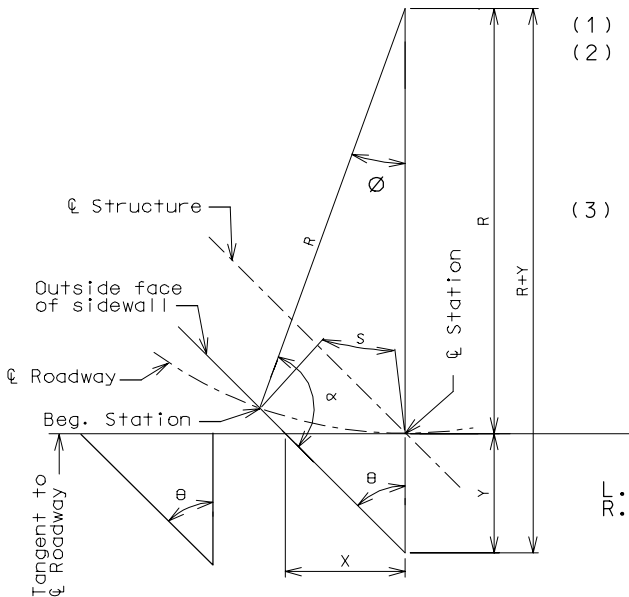

(1) $x \cot \theta = Y$
 (2) $\frac{\sin \theta}{R} = \frac{\sin \alpha}{(R+Y)}$
 $\sin \alpha = \frac{\sin \theta}{R} (R+Y)$
 Find θ
 (3) $S = R\theta$

L.A. Skews Curve Rt.
 R.A. skews Curve Lt.

Figure 3.20.4.3-1. Details and Sample Calculation of Beginning Station

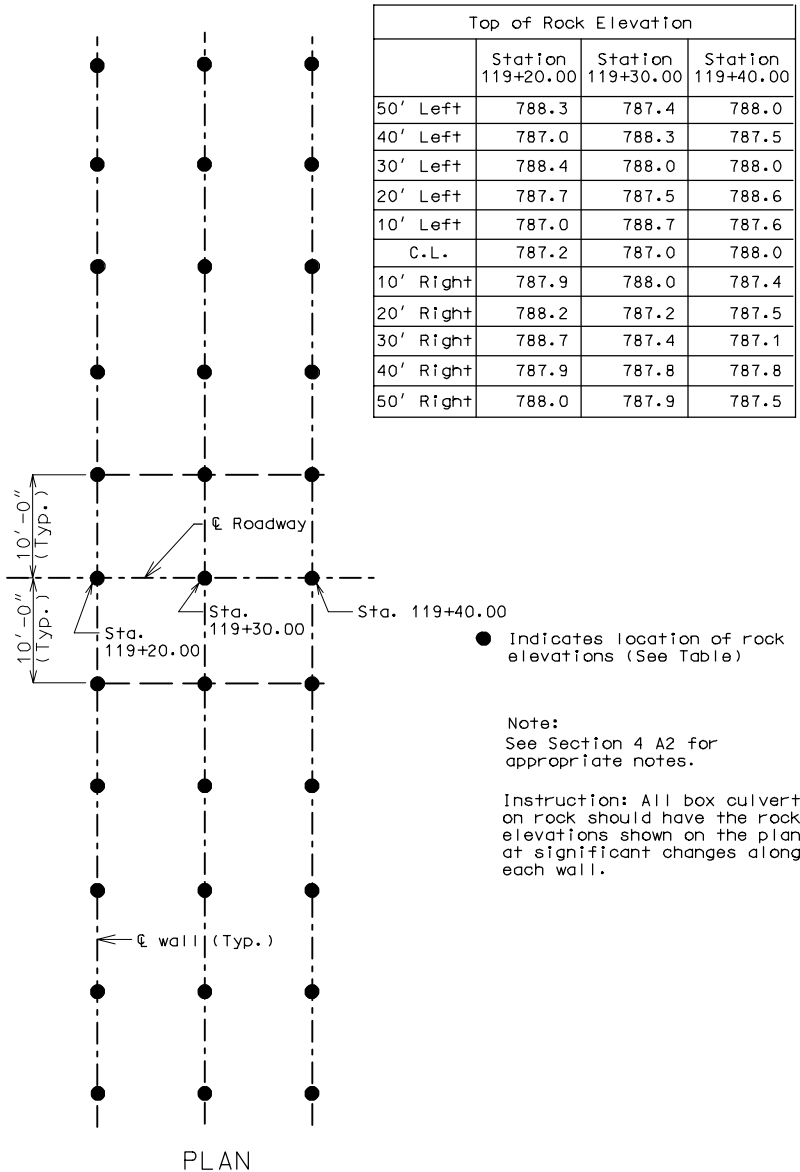
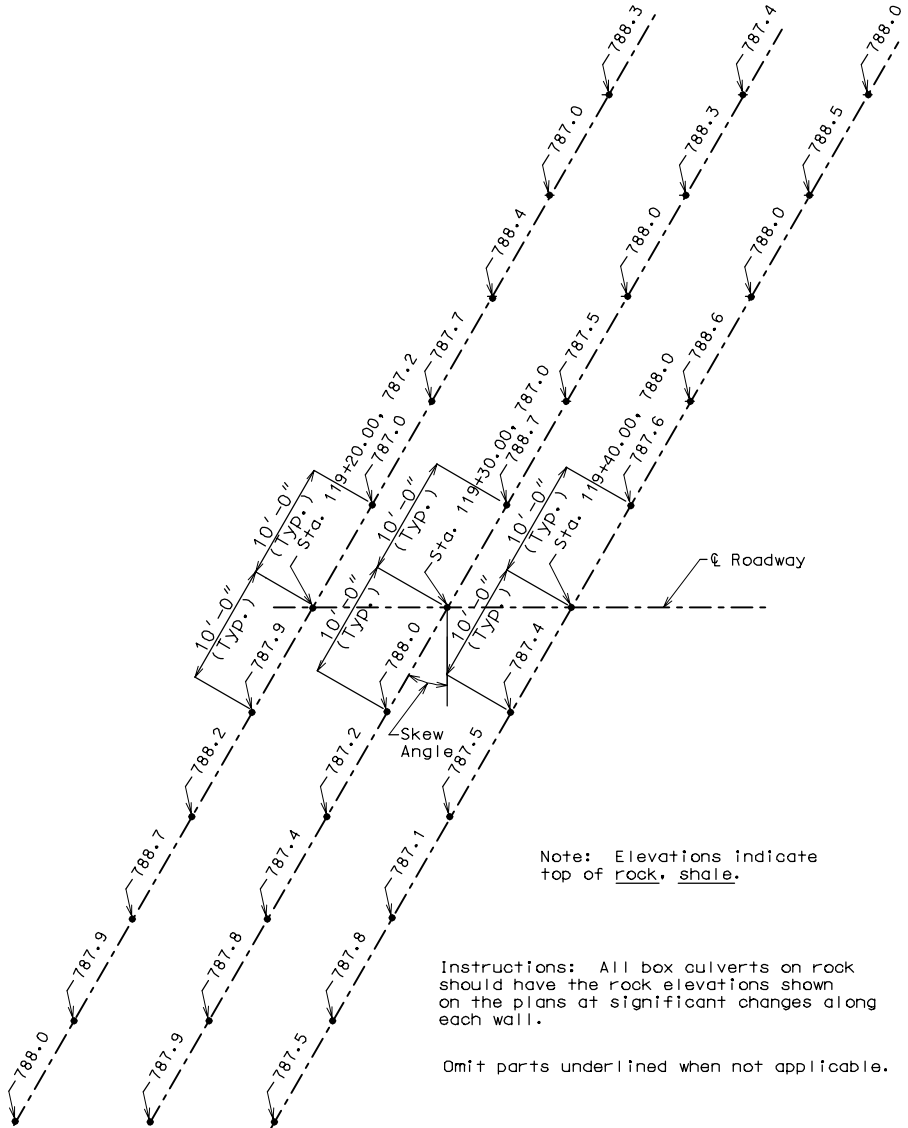

Figure 3.20.4.3-2. Details of Plan Showing Rock Elevations for Alternate #1



PLAN

Figure 3.20.4.3-3. Details of Plan Showing Rock Elevations for Alternate #2

4.4 Miscellaneous**Granular Backfill**

The contractor shall furnish granular backfill in accordance with Sec 206 within the limits as shown on the plans when approved by the engineer. Payment for removal of inherently unsound material will be made at the contract unit price for Class 4 Excavation. The contractor will be reimbursed for the delivered cost of granular backfill when approved by the engineer.

Wing Backfill Slope Transition

Backfill slope transition at wings is determined base on skew angle of box culvert. See Missouri Standard Plans for Construction, standard drawing 703.37 page 2 of 2 for slope transition.

Culvert Extensions

When an existing culvert needs to be extended for a new section, cutting details shall be followed to determine where and how to cut the existing culvert. See Missouri Standard Plans for Construction, standard drawing 703.38 for cutting details.