

# MISSOURI HIGHWAYS AND TRANSPORTATION COMMISSION PLANS FOR PROPOSED STATE HIGHWAY

## INDEX OF SHEETS

DESCRIPTION	SHEET NUMBER
TITLE SHEET -----	1
TYPICAL SECTIONS (TS) (1 SHEET)--	2
QUANTITIES (QU) (1 SHEET)-----	3
PLAN (PP)-----	4
TRAFFIC CONTROL SHEETS (TC)-----	5-7

\*THIS MEDIA SHOULD NOT BE CONSIDERED A CERTIFIED DOCUMENT.\*

DATE PREPARED  
01/16/2009

ROUTE STATE  
MO MO

DISTRICT SHEET NO.  
1 1

COUNTY

JOB NO.

CONTRACT ID.

PROJECT NO.

BRIDGE NO.

NO.	DATE	DESCRIPTION

### LENGTH OF PROJECT

BEGINNING OF PROJECT \_\_\_\_\_

END OF PROJECT \_\_\_\_\_

APPARENT LENGTH \_\_\_\_\_ MILES

EQUATIONS AND EXCEPTIONS:

TOTAL CORRECTIONS \_\_\_\_\_

NET LENGTH OF PROJECT \_\_\_\_\_

STATE LENGTH \_\_\_\_\_

MISSOURI HIGHWAYS AND TRANSPORTATION COMMISSION

105 WEST CAPITOL  
JEFFERSON CITY, MO 65102  
1-888-ASK-MODOT (1-888-275-6636)

IF A SEAL IS PRESENT ON THIS SHEET IT HAS BEEN ELECTRONICALLY SEALED AND DATED.

"THIS MEDIA SHOULD NOT BE CONSIDERED A CERTIFIED DOCUMENT."

DATE PREPARED  
01/16/2009

ROUTE STATE  
MO MO

DISTRICT SHEET NO.

COUNTY

JOB NO.

CONTRACT ID.

PROJECT NO.

BRIDGE NO.

DESCRIPTION

DATE

MISSOURI HIGHWAYS AND TRANSPORTATION COMMISSION



IF A SEAL IS PRESENT ON THIS SHEET IT HAS BEEN ELECTRONICALLY SEALED AND DATED.

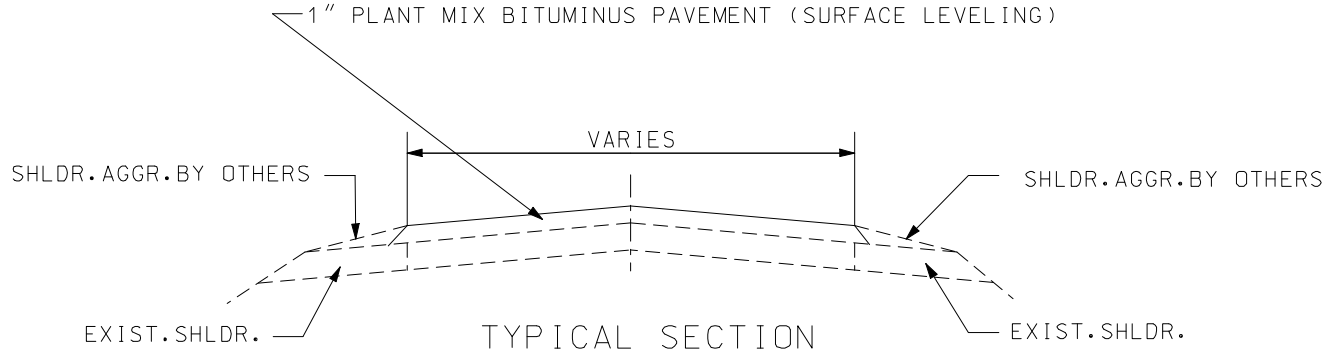

STRIPING TO BE COMPLETED BY OTHERS.

NOTIFY ENGINEER TWO WEEKS PRIOR TO PROJECT COMPLETION

NOTE: SURFACE PLACEMENT SHALL BE ONE PASS PER LANE  
NO S.E. CORRECTION.

TYPICAL SECTION  
SHEET 1 OF 1

## MISSOURI HIGHWAYS AND TRANSPORTATION COMMISSION

### SUMMARY OF QUANTITIES

\*THIS MEDIA SHOULD NOT BE CONSIDERED A CERTIFIED DOCUMENT.\*

DATE PREPARED  
8/4/2010

ROUTE STATE  
MO

DISTRICT SHEET NO.  
3

COUNTY

JOB NO.

CONTRACT ID.

PROJECT NO.

BRIDGE NO.

DESCRIPTION

DATE

MISSOURI HIGHWAYS AND TRANSPORTATION COMMISSION



100 WEST CAPITOL  
JEFFERSON CITY  
1-888-ASK-MDOT (1-888-275-6363)

IF A SEAL IS PRESENT ON THIS SHEET IT HAS BEEN ELECTRONICALLY SEALED AND DATED.

#### BITUMINOUS PAVEMENT SURFACE LEVELING PG64-22

LOG MILE	LOG MILE	NET LENGTH MILES	AVERAGE WIDTH FEET	QUANTITY 1.987 Tons/CY TONS	TACK .05 GAL/SQ. YD. GALLONS	REMARKS
TRAVELWAY - ROUTE 156						
TOTALS						

#### MODIFIED COLD MILLING (DEPTH TRANSITION)

LOG MILE	LOG MILE	QUANTITY SQ. YD.	REMARKS
TOTAL			

#### BITUMINOUS PAVEMENT SURFACE LEVELING PG64-22 (INTERSECTIONS/ENTRANCES)

LOG MILE	NET LENGTH MILES	AVERAGE WIDTH FEET	QUANTITY 1.987 Tons/CY TONS	TACK .05 GAL/SQ. YD. GALLONS	REMARKS
STATE ROUTE ENTRANCES					
TOTALS					*included in surfacing totals

#### STATE ROUTE ENTRANCES

TOTAL			

#### FLAG ASSEMBLIES

	QUANTITY EACH	REMARKS
TOTAL		

#### TEMPORARY RAISED PAVEMENT MARKER, TYPE 2

LOG MILE	LOG MILE	QUANTITY EACH	REMARKS
TOTAL			

NOTE: FINAL STRIPING DONE BY OTHERS. TEMPORARY PAV'T MARKERS TO BE REMOVED BY CONTRACTOR AFTER FINAL STRIPING

#### CONSTRUCTION SIGNING

SIGN NO.	SIGN	SIZE (In.)	AREA (ft. <sup>2</sup> )	QTY.	TOTAL AREA (ft. <sup>2</sup> )	DESCRIPTION
②**	W020-1	48 x 48	16.00	X	XXX	ROAD WORK AHEAD
⑦	W020-4	48 x 48	16.00	4	64	ONE LANE ROAD AHEAD
⑧	W020-7a	48 x 48	16.00	4	64	FLAGGER (SYMBOL) (WITH FLAGS)
④ & ②⑤	R2-1	36 x 48	12.00	8	96	SPEED LIMIT XX ④ 3-35 MPH ②⑤ 3-55
⑤⑨	G023-1	36 x 12	3.00	4	12	WORK ZONE PLAQUE
③	W3-5	36 x 36	9.00	4	36	REDUCED SPEED AHEAD (SYMBOL) ③ 3-35 MPH
①*	G020-1	60 x 24	10.00	2	20	ROAD WORK NEXT XX MILES ① 2-8 MILES
②⑥	G020-2a	48 x 24	8.00	2	16	END ROAD WORK
⑤⑨	W08-12	36 x 36	9.00	X	XX.XX	NO CENTER STRIPE
616-10.05 CONSTRUCTION SIGNS TOTAL					XXX.XX	

\* IF LESS THAN TWO (2) MILES, DELETE SIGN NO. 1.

\*\* ADDITIONAL SIGN NO. 2 USED AS SHOWN ON TRAFFIC CONTROL SHEET 2 OF 3 AND AS DIRECTED BY ENGINEER.

NOTE:

REFER TO STANDARD PLAN 616.10 AND 903.03 FOR SIGN AND SIGN MOUNTING REQUIREMENTS.

ITEM NO.	QTY.	DESCRIPTION
616-11.20	2	INSTALLATION OF 48" X 48" "DRIVE SMART SIGN"

SUMMARY SHEET  
SHEET 1 OF 1



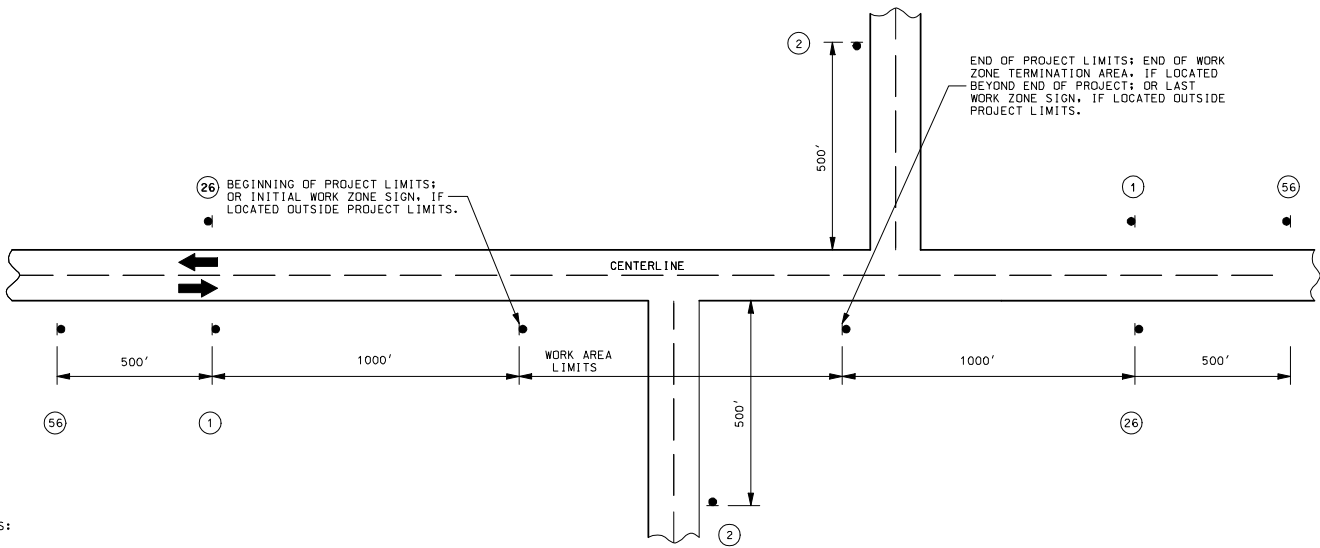

END OF PROJECT LIMITS; END OF WORK ZONE TERMINATION AREA. IF LOCATED BEYOND END OF PROJECT; OR LAST WORK ZONE SIGN, IF LOCATED OUTSIDE PROJECT LIMITS.

(26) BEGINNING OF PROJECT LIMITS; OR INITIAL WORK ZONE SIGN, IF LOCATED OUTSIDE PROJECT LIMITS.

**NOTES:**

- SIGN (1) IS ONLY USED ON PROJECT LENGTHS 2 MILES OR GREATER.
- SIGN (26) MAY BE USED ON PROJECTS LESS THAN 2 MILES.
- PROVIDE SIGNS IN EACH DIRECTION ON TWO-WAY HIGHWAY.
- DISTANCE MAY BE ADJUSTED ACCORDING TO FIELD CONDITIONS.



CONST-6-48

(56)

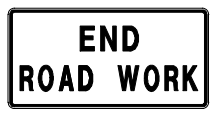

G020-2a

(26)



G020-1

(01)



W020-1

(02)

"THIS MEDIA SHOULD NOT BE CONSIDERED A CERTIFIED DOCUMENT."

DATE PREPARED 01/16/2009	
ROUTE MO	STATE MO
DISTRICT C	SHEET NO. C
COUNTY	
JOB NO.	
CONTRACT ID.	
PROJECT NO.	
BRIDGE NO.	

DESCRIPTION	DATE

MISSOURI HIGHWAYS AND TRANSPORTATION COMMISSION  
 105 WEST CAPITOL  
 JEFFERSON CITY, MO 65102  
 1-888-ASK-MODOT (1-888-275-6636)

TRAFFIC CONTROL  
SHEET 1 OF 3

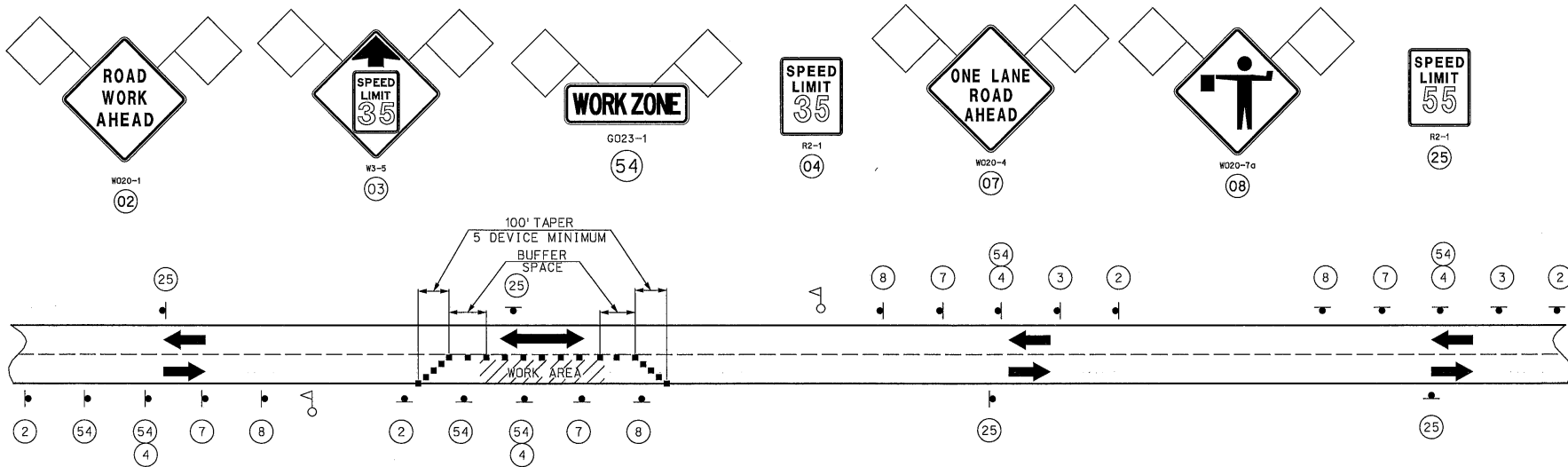

SET 1  
ACTIVE

SET 2  
INACTIVE

SET 3  
ACTIVE

SET 4  
INACTIVE

SIGN SETS 1 AND 3 ARE ACTIVE AND (I.E., SIGNS FACE ONCOMING TRAFFIC).

SIGN SETS 2 AND 4 ARE INACTIVE (I.E., SIGNS DO NOT FACE EITHER DIRECTION OF TRAFFIC) WHEN THE RESURFACING OPERATION IS LOCATED BETWEEN SIGN SETS 1 AND 3.

WHEN SIGN SETS 2 AND 4 ARE ACTIVE, SIGN SETS 1 AND 3 BECOME INACTIVE AND ARE ADVANCED TO BECOME SETS 2 AND 4 WITH SIGN LEGENDS TURNED AWAY FROM BOTH DIRECTIONS OF TRAFFIC. WHEN THE RESURFACING OPERATION ADVANCES TO BETWEEN SIGN SETS 2 AND 4, SIGN SETS 2 AND 4 BECOME ACTIVE (I.E., NEW SIGN SETS 1 AND 3) AND SIGN SETS 1 AND 3 ADVANCED IN THE DIRECTION OF THE OPERATION (I.E., NEW SIGN SETS 2 AND 4).

■ - CHANNELIZERS

◡ - FLAGGER

NOTES:

DAYLIGHT FLAGGING OPERATIONS ONLY.

CHANNELIZING DEVICES LOCATED DOWNSTREAM OF THE ONE-LANE, TWO-WAY TAPER ARE OPTIONAL. THESE DEVICES SHOULD BE ELIMINATED WHEN THEIR USE WILL REDUCE THE USABLE LANE WIDTH, INCLUDING ANY ACCEPTABLE SHOULDERS, TO LESS THAN 10' OR WILL SIGNIFICANTLY AFFECT THE RESURFACING OPERATION.

FLAG ASSEMBLIES FOR SIGNS WILL BE PAID FOR AS EACH PER SIGN, EXCEPT FOR SIGN W020-7A WHICH IS SUBSIDIARY TO THE SIGN.

SIGN SPACING FOR ADVANCE SIGN SERIES (2) (3)		
SPEED (1) MPH	NON-DIVIDED HIGHWAYS	DIVIDED HIGHWAYS
0 - 35	200	200
40 - 45	350	500
50 - 55	500	1000
60 - 70	1000	1000

NOTES:  
NOTES:

DIMENSIONS IN FEET UNLESS OTHERWISE NOTED.

(1) POSTED SPEED LIMIT PRIOR TO ROAD WORK.

(2) SPACING BETWEEN SIGNS, BETWEEN LAST SIGN AND FLAGGER, BEGINNING OF TAPER OR SIGNED CONDITION.

(3) SPACINGS MAY BE ADJUSTED AS NECESSARY TO MEET FIELD CONDITIONS.

TRAFFIC CONTROL  
SHEET 2 OF 3

"THIS MEDIA SHOULD NOT BE CONSIDERED A CERTIFIED DOCUMENT."

DATE PREPARED  
8/4/2010

ROUTE STATE  
MO

DISTRICT SHEET NO.  
6

COUNTY

JOB NO.

CONTRACT ID.

PROJECT NO.

BRIDGE NO.

DESCRIPTION

DATE

MISSOURI HIGHWAYS AND TRANSPORTATION COMMISSION



IF A SEAL IS PRESENT ON THIS SHEET IT HAS BEEN ELECTRONICALLY SEALED AND DATED.

REV.

"THIS MEDIA SHOULD NOT BE CONSIDERED A CERTIFIED DOCUMENT."

DATE PREPARED  
8/5/2010

ROUTE STATE  
MO MD

DISTRICT SHEET NO.  
7

COUNTY

JOB NO.

CONTRACT ID.

PROJECT NO.

BRIDGE NO.

DATE	DESCRIPTION

DATE

DESCRIPTION

MISSOURI HIGHWAYS AND TRANSPORTATION COMMISSION  
  
 105 WEST CAPITAL  
 JEFFERSON CITY, MO 66102  
 1-888-ASK-MDOT (1-888-275-6688)

TRAFFIC CONTROL PLAN

IF A SEAL IS PRESENT ON THIS SHEET IT HAS BEEN ELECTRONICALLY SEALED AND DATED. REV.

"NO CENTER STRIPE" SIGNS

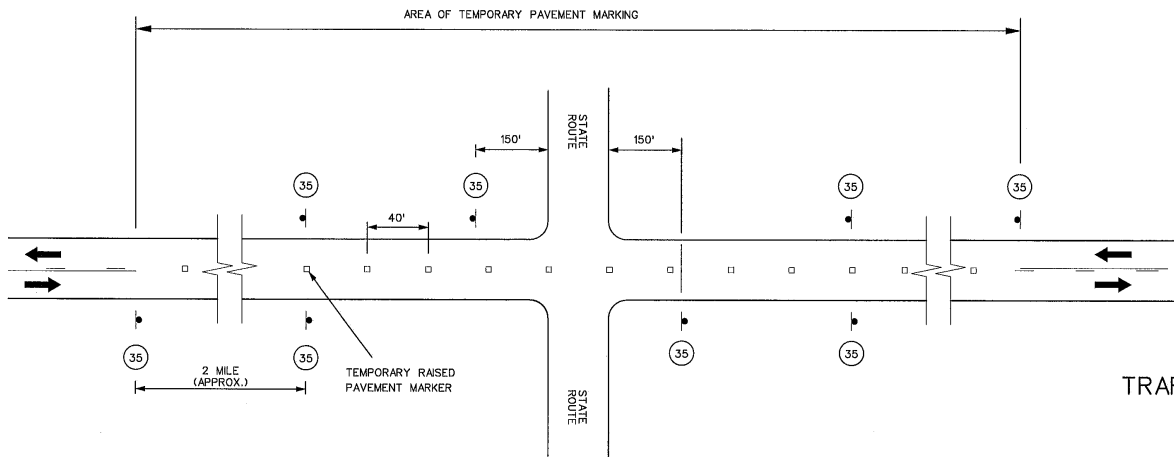

TRAFFIC CONTROL PLAN

- NOTES:
- SIGN (35) AND TEMPORARY PAVEMENT MARKING INSTALLED WHERE CENTER STRIPING HAS BEEN COVERED OR REMOVED. SIGNS ARE TO REMAIN IN PLACE UNTIL THE PERMANENT CENTER PAVEMENT MARKINGS ARE IN PLACE. SIGNS SHALL BE COVERED OR REMOVED WHEN PERMANENT CENTER PAVEMENT MARKING HAS BEEN INSTALLED.
  - SIGN (35) IS PLACED AT APPROXIMATELY TWO MILE INTERVALS AND AT STATE ROUTES WHEN SIGN (35) IS INSTALLED AT A STATE ROUTE, ANY OTHER SIGN (35) LOCATED WITHIN ONE-EIGHTH OF A MILE FROM THE SIDE ROAD MAY BE DELETED.
  - SIGN (35) SHALL BE POST MOUNTED IN ACCORDANCE WITH STANDARD PLANS 616.10 AND 903.03.
  - TEMPORARY RAISED PAVEMENT MARKERS SHALL BE INSTALLED BY THE END OF EACH DAY.